

| REV | ECN NO. | DESCRIPTION | DATE | DRAWN |
|-----|---------|----------------------------------|----------|------------|
| B/0 | N/A | ADD 03,05,07,08PIN SPECIFICATION | 05/15/17 | Ziwen Kong |
| B/1 | N/A | MODIFY TOLERANCE(PITCH,A,B,C,D) | 05/18/17 | Ziwen Kong |
| B/2 | N/A | ADD 11,12 SPECIFICATION | 08/23/17 | Cong Wang |

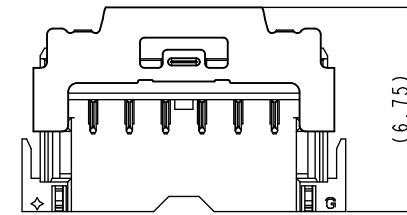

Shell Unlock Condition (REF.)

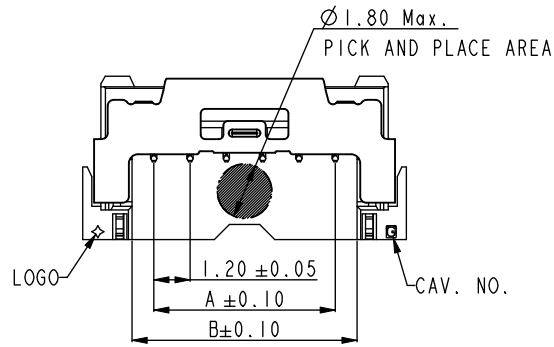
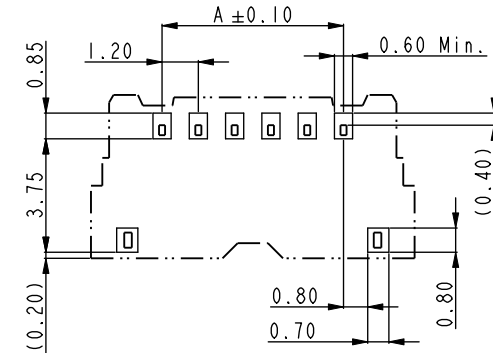

TOLERANCE: ±0.05
RECOMMENDED P.C.B. Layout
TOP VIEW

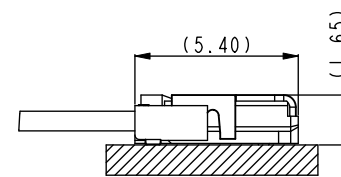
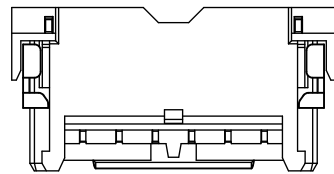
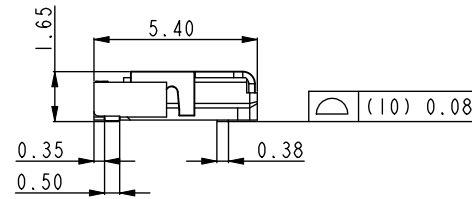
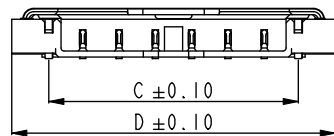

Mating Condition (REF.)

| PIN | A | B | C | D |
|-----|-------|-------|-------|-------|
| 02 | -- | 2.64 | 3.45 | 5.90 |
| 03 | 2.40 | 3.84 | 4.65 | 7.10 |
| 04 | 3.60 | 5.04 | 5.85 | 8.30 |
| 05 | 4.80 | 6.24 | 7.05 | 9.50 |
| 06 | 6.00 | 7.44 | 8.25 | 10.70 |
| 07 | 7.20 | 8.64 | 9.45 | 11.90 |
| 08 | 8.40 | 9.84 | 10.65 | 13.10 |
| 09 | 9.60 | 11.04 | 11.85 | 14.30 |
| 10 | 10.80 | 12.24 | 13.05 | 15.50 |
| 11 | 12.00 | 13.44 | 14.25 | 16.70 |
| 12 | 13.20 | 14.64 | 15.45 | 17.90 |

| 1 | CONTACT | COPPER ALLOY, ±0.20mm | GOLD FLASH PLATED ON CONTACT AREA, OVER NICKEL |
|-------|------------|--|--|
| 2 | INSULATION | LCP, UL94V-0(HALOGEN FREE) COLOR: BLACK | |
| 3 | SHELL | STAINLESS STEEL, ±0.20mm | |
| 4 | SOLDER TAB | COPPER ALLOY, ±0.25mm | MATTE TIN PLATED OVER NICKEL |
| INDEX | PART NAME | MATERIAL | FINISH |

NOTES

- MATES WITH: 2WBI202HNO-NPK HOUSING
- ORDERING CODE: 2WBI202WNV-XX020IH16

NO. OF PINS
02: 2 PINS
03: 3 PINS
...
SMT WITH LATCH TYPE

TAPE REEL PACKING
INSULATOR COLOR: BLACK
INSULATION MATERIAL:
LCP, UL94V-0
SEE CONTACT FINISH

TOLERANCE

X.X ±0.25
X.XX ±0.15
ANGULA 3°

UNLESS OTHERWISE SPECIFIED

Singatron Enterprise Co., Ltd.

| | | | | |
|-------|--|----------|----------------------|----------|
| TITLE | WIRE TO BOARD, PITCH 1.20 mm, VERTICAL, SINGLE ROW, SMT TYPE ASSEMBLY | | | |
| DWN | Cong Wang | PART NO. | 2WBI202WNV-XX020IH16 | |
| CHKD | Paul Chen | SCALE | 1:1 | UNIT: mm |
| APVD | Wayne La | SIZE: A3 | SHEET 1 OF 4 | REV: B/2 |

CUSTOMER COPY

1

2

3

4

5

6

7

8



| REV | ECN NO. | DESCRIPTION | DATE | DRAWN |
|-----|---------|----------------------------------|-----------|------------|
| B/0 | N/A | ADD 03,05,07,08PIN SPECIFICATION | 05/15/17' | Ziwen Kong |
| B/1 | N/A | MODIFY TOLERANCE(PITCH,A,B,C,D) | 05/18/17' | Ziwen Kong |
| B/2 | N/A | ADD 11,12 SPECIFICATION | 08/23/17' | Cong Wang |

F

E

D

C

B

A

02

03

04

06

05,07~12

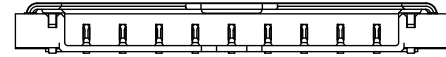
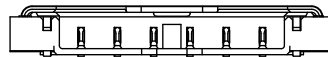
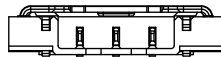
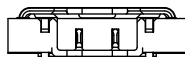
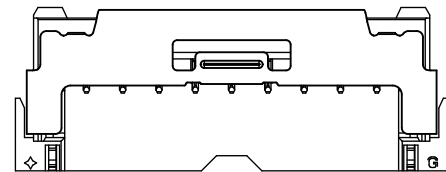
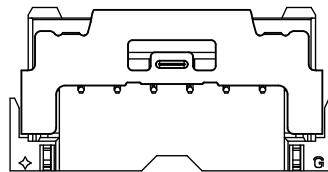
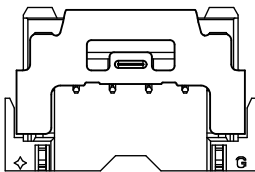
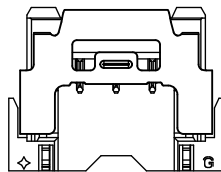
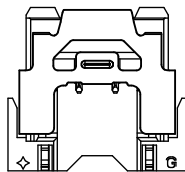

Singatron Enterprise Co., Ltd.

TOLERANCE
 X.X ±0.25
 X.XX ±0.15
 ANGULA 3°
 UNLESS OTHERWISE SPECIFIED

| | | | | |
|-------|---|----------|----------------------|----------|
| TITLE | WIRE TO BOARD, PITCH 1.20 mm, VERTICAL, SINGLE ROW, SMT TYPE ASSEMBLY | | | |
| DWN | Cong Wang | PART NO. | 2WBI202WNV-XX0201H16 | |
| CHKD | Paul Chen | SCALE | 1:1 | UNIT: mm |
| APVD | Wayne La | SIZE: A3 | SHEET 2 OF 4 | REV: B/2 |

CUSTOMER COPY

1

2

3

4

5

6

7

8



| REV | ECN NO. | DESCRIPTION | DATE | DRAWN |
|-----|---------|----------------------------------|----------|------------|
| B/0 | N/A | ADD 03,05,07,08PIN SPECIFICATION | 05/15/17 | Ziwen Kong |
| B/1 | N/A | MODIFY TOLERANCE(PITCH,A,B,C,D) | 05/18/17 | Ziwen Kong |
| B/2 | N/A | ADD 11,12 SPECIFICATION | 08/23/17 | Cong Wang |

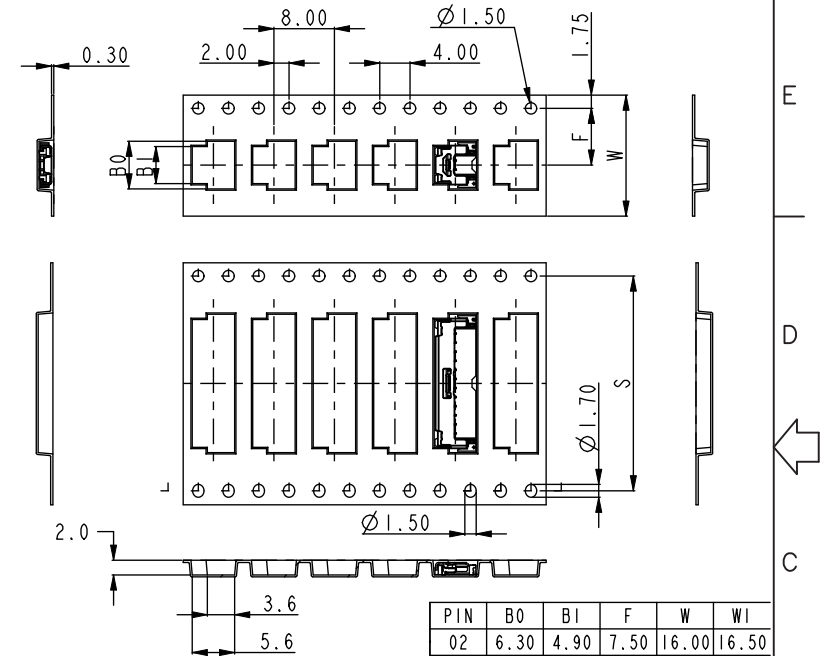
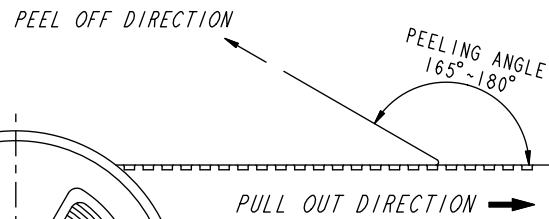
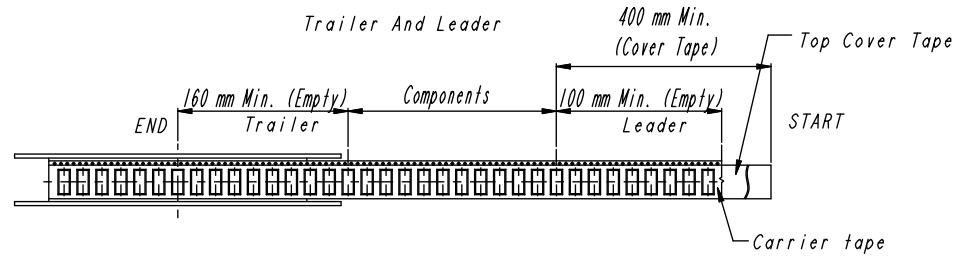

| PIN | B0 | B1 | F | W | WI |
|-----|-------|-------|-------|-------|-------|
| 02 | 6.30 | 4.90 | 7.50 | 16.00 | 16.50 |
| 03 | 7.50 | 6.10 | 7.50 | 16.00 | 16.50 |
| 04 | 8.70 | 7.30 | 7.50 | 16.00 | 16.50 |
| 05 | 9.90 | 8.50 | 11.50 | 24.00 | 24.50 |
| 06 | 11.10 | 9.70 | 11.50 | 24.00 | 24.50 |
| 07 | 12.30 | 10.90 | 11.50 | 24.00 | 24.50 |
| 08 | 13.50 | 12.10 | 11.50 | 24.00 | 24.50 |
| 09 | 14.70 | 13.30 | 11.50 | 24.00 | 24.50 |
| 10 | 15.90 | 14.50 | 11.50 | 24.00 | 24.50 |
| 11 | 17.10 | 15.70 | 11.50 | 24.00 | 24.50 |
| 12 | 18.30 | 16.90 | 14.20 | 32.00 | 32.50 |

TOLERANCE
 X.X ±0.25
 X.XX ±0.15
 ANGULA 3°
 UNLESS OTHERWISE SPECIFIED

| | | | | |
|---------------------------------------|---|-----------------|----------------------|-------------------------------------|
| Singatron Enterprise Co., Ltd. | | | | |
| TITLE | WIRE TO BOARD, PITCH 1.20 mm, VERTICAL, SINGLE ROW, SMT TYPE ASSEMBLY | | | |
| DWN | Cong Wang | PART NO. | 2WB1202WNV-XX0201H16 | |
| CHKD | Paul Chen | SCALE | 1:1 | UNIT: mm |
| APVD | Wayne La | SIZE: | A3 | SHEET 3 OF 4 REV: B/2 |
| CUSTOMER COPY | | | | |

1 2 3 4 5 6 7 8

| REV | ECN NO. | DESCRIPTION | DATE | DRAWN |
|-----|---------|----------------------------------|----------|------------|
| B/0 | N/A | ADD 03,05,07,08PIN SPECIFICATION | 05/15/17 | Ziwen Kong |
| B/1 | N/A | MODIFY TOLERANCE(PITCH,A,B,C,D) | 05/18/17 | Ziwen Kong |
| B/2 | N/A | ADD 11,12 SPECIFICATION | 08/23/17 | Cong Wang |

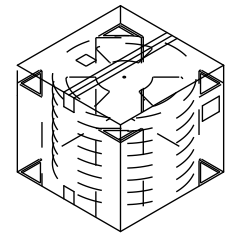
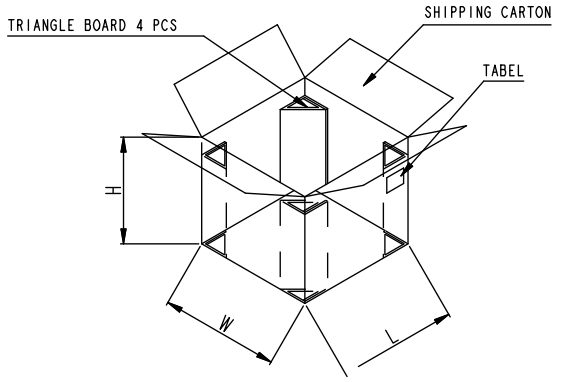
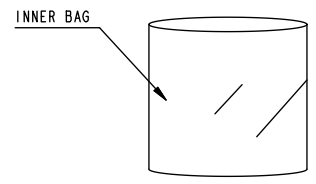
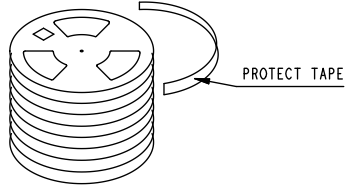
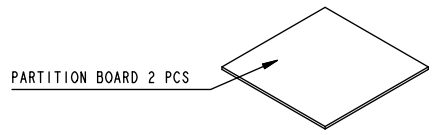

| PIN, Q'TY/REEL, REEL DIM.(mm) | PIN, REEL/BC, PCS/BC, CARTON DIM. |
|---|--|
| 2~12P, 4000 PCS/REEL, $\varnothing 330 \times (W+0.50)$ | 2~4P, 14 RE, 56000 PCS/BC, 350*350*340 mm 6~11P, 10 RE, 40000 PCS/BC, 350*350*340 mm 12P, 8 RE, 32000 PCS/BC, 350*350*340 mm |

F
E
D
C
B
A

F
E
D
C
B
A

TOLERANCE
 X.X ±0.25
 X.XX ±0.15
 ANGULA 3°
 UNLESS OTHERWISE SPECIFIED

| | | | |
|---------------------------------------|---|----------|-----------------------|
| Singatron Enterprise Co., Ltd. | | | |
| TITLE | WIRE TO BOARD, PITCH 1.20 mm, VERTICAL, SINGLE ROW, SMT TYPE ASSEMBLY | | |
| DWN | Cong Wang | PART NO. | 2WB1202WNV-XX0201H16 |
| CHKD | Paul Chen | SCALE | 1:1 UNIT: mm |
| APVD | Wayne La | SIZE: A3 | SHEET 4 OF 4 REV: B/2 |
| CUSTOMER COPY | | | |

1 2 3 4 5 6 7 8