

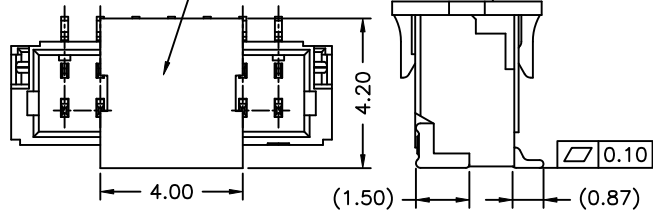

CAP
(FOR PICK AND
PLACE SYSTEMS)



P/N LEGEND

- 2WBA1001 WV-S-XP N 6 B XX X S2 L
- ① Series No.
 - ② Connector type: WV=Vertical
 - ③ Mounting type: S=SMT without boss
 - ④ No. of circuits
 - ⑤ N=Halogen Free
 - ⑥ Material: 6=Nylon 6T
 - ⑦ Color: B=Black
 - ⑧ Plating code for contacts:
T1=Matte Tin-plated; G1=Gold-flash
 - ⑨ Plating code for solder tabs:
T=Matte Tin-plated; G=Gold-flash
 - ⑩ Option code: S2=For Wistron Tape & Reel
 - ⑪ Packing code: L=Tape & Reel(With Cap)

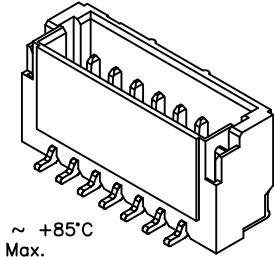
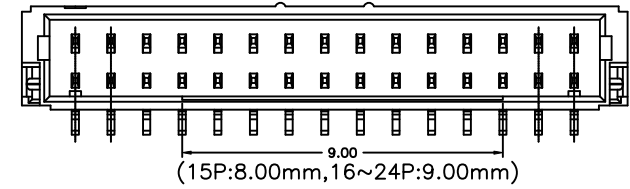

SPECIFICATIONS

Current Rating: 1A AC,DC
Voltage Rating: 50V AC,DC
Temperature Range: -25°C ~ +85°C
Contact Resistance: 20mΩ Max.
Insulation Resistance: 100MΩ Min.
Withstanding Voltage: 500V AC/minute
Pin Material: Phosphor Bronze
Solder Tabs: Brass
Material: Nylon 6T,UL94V-0
Cap: Nylon 6T,UL94V-0,Natural(Black)

F
E
D
C
B
A

F
E
D
C
B
A

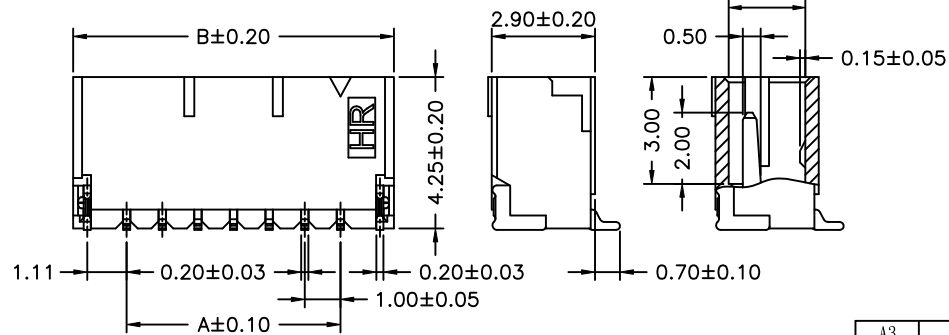
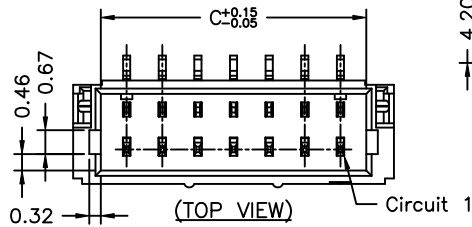
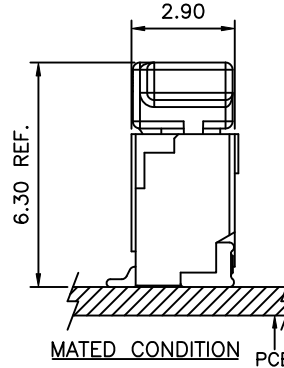
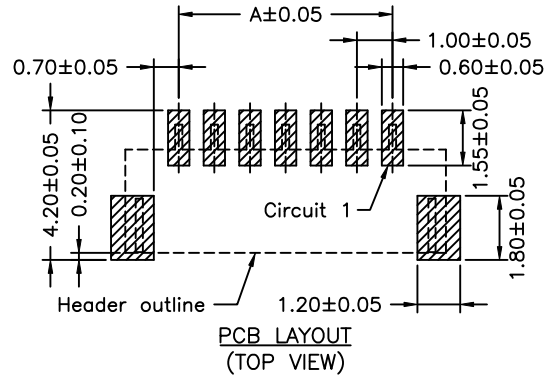
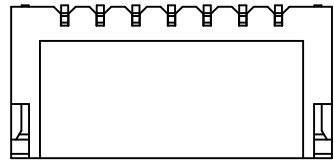

Circuit No.	Dimensions		
	A	B	C
04P	3.00	6.00	4.45
05P	4.00	7.00	5.45
06P	5.00	8.00	6.45
14P	13.00	16.00	14.45
19P	18.00	21.00	19.45
20P	19.00	22.00	20.45

Singatron Enterprise Co., Ltd.			
TITLE	1.00mm PITCH 180° WAFER-SMT TYPE		
DWN	陳錦展 2010.12.01	PART NO. 2WBA1001WV-S-XP6BXXXS2L	
CHKD		SCALE 1:1	UNIT: mm
APVD	黃正一 2010.12.01	SIZE: A3	SHEET: 1 OF 2 REV: A3
CUSTOMER COPY			

REV.	DESCRIPTION	DATE	NAME	GENERAL TOLERANCE
A3	ECN1706160003	2017.06.30	向瑞	X.X±0.25 X.XX±0.15 X.XXX±0.05
A2	EN1110110449	2011.11.29	陳敏	
A1	EN1106240218	2011.06.24	陳敏	
A0	NEW RELEASE	2010.12.01	陳錦展	



04~14 Contacts

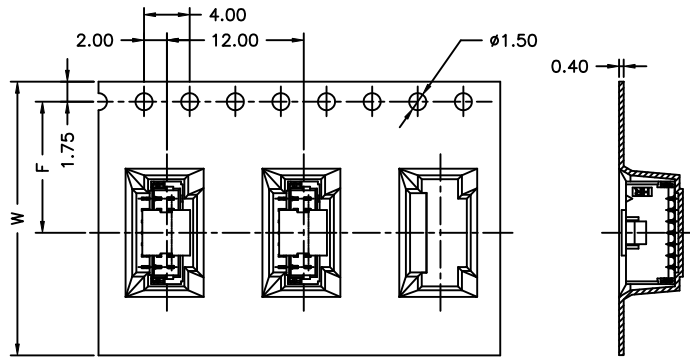

Unreeing direction →

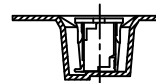

06~13 Contacts

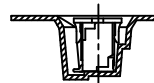

02~05 Contacts

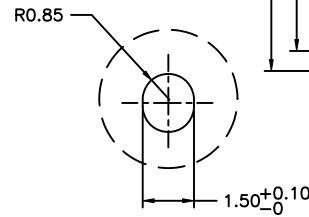

19~20 Contacts

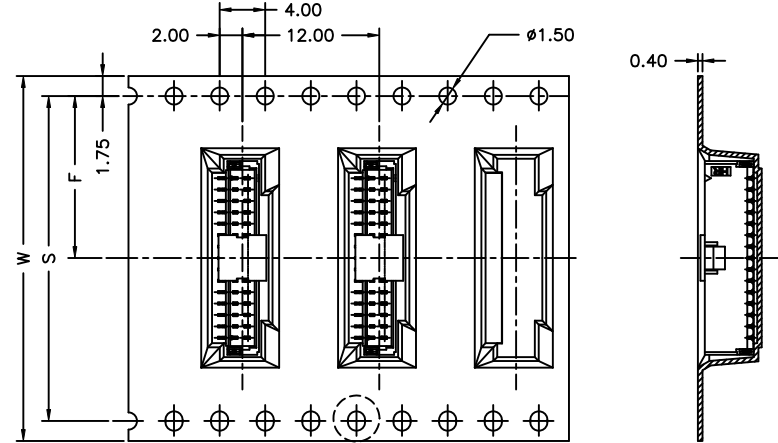

Unreeing direction →

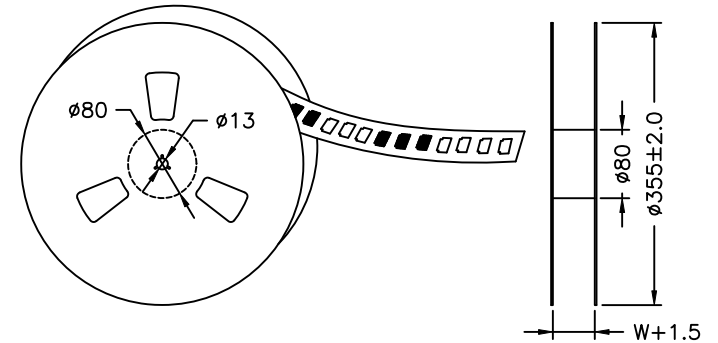
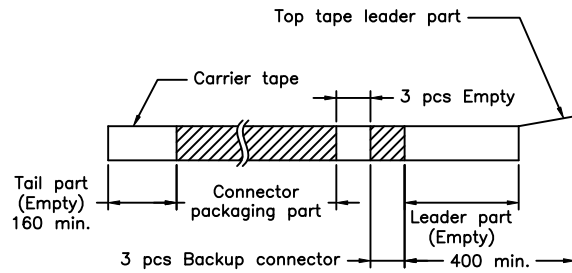

NOTE:
Material: Transparent
Anti-static Polystyrene.

Number of Contacts	W±0.3	F±0.1	S±0.1	Q'ty/Reel
04P	16	7.50	/	1,000
05P	16	7.50		1,000
06P	16	7.50		1,000
14P	24	11.50		1,000
19P	32	14.20	28.40	1,000
20P	32	14.20	28.40	1,000

REV.	DESCRIPTION	DATE	NAME	GENERAL TOLERANCE
A3	ECN1706160003	2017.06.30	向瑞	X.X±0.25 X.XX±0.15 X.XXX±0.05
A2	EN110110449	2011.11.29	陳敏	
A1	EN1106240218	2011.06.24	陳敏	
A0	NEW RELEASE	2010.12.01	陳錦展	

Singatron Enterprise Co., Ltd.			
TITLE	1.00mm PITCH 180° WAFER-SMT TYPE		
DWN	陳錦展 2010.12.01	PART NO. 2WBA1001WV-S-XPN6BXXS2L	
CHKD		SCALE 1:1	UNIT: mm
APVD	董正一 2010.12.01	SIZE: A3	SHEET: 2 OF 2
REV: A3			
CUSTOMER COPY			