

P/N LEGEND

- 2WBA1253 WRA-S-XP XXX
- ① Series No.
② Connector type: WR=Right angle A type
③ Mounting type: S=SMT Type
④ No. of circuits
⑤ Option code:
Blank=Contacts/Matte Tin-plated
Solder Tabs/Matte Tin-plated
D01=Contacts/Gold-flash and
Solder tabs/Gold-flash
D20=Contacts/Gold-flash and
Solder tabs/Gold-flash With Mylar
C=Contacts/Matte Tin-plated
Solder Tabs/Matte Tin-plated With Mylar

SPECIFICATIONS
Current Rating: 1A AC,DC
Voltage Rating: 150V AC,DC
Temperature Range: -25°C ~ +85°C
Contact Resistance: 20mΩ Max.
Insulation Resistance: 500MΩ Min.
Withstanding Voltage: 500V AC/minute
Pin Material: Brass
Solder Tabs: Brass
Material: Nylon 6T,UL94V-0
Color: Natural(Beige)

Circuit No.	Dimensions		
	A	B	C
02P	1.25	7.45	3.50
03P	2.50	8.70	3.50
04P	3.75	9.95	3.50
05P	5.00	11.20	3.50
06P	6.25	12.45	3.50
07P	7.50	13.70	3.50
08P	8.75	14.95	3.50
09P	10.00	16.20	3.50
10P	11.25	17.45	3.50
11P	12.50	18.70	5.00
12P	13.75	19.95	5.00
13P	15.00	21.20	5.00
14P	16.25	22.45	5.00
15P	17.50	23.70	5.00
16P	18.75	24.95	5.00
20P	23.75	29.95	5.00
25P	30.00	36.20	6.00
30P	36.25	42.45	6.00

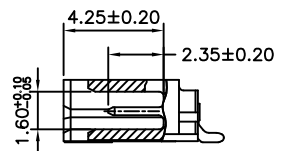
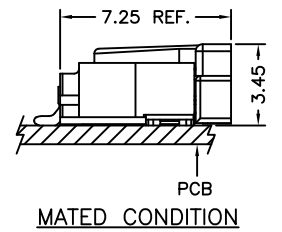
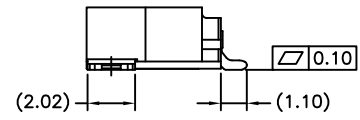
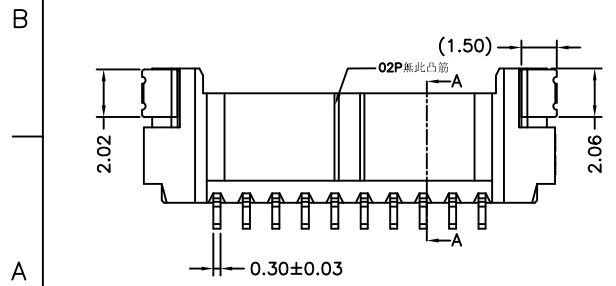
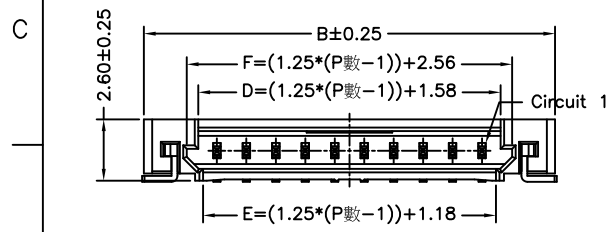
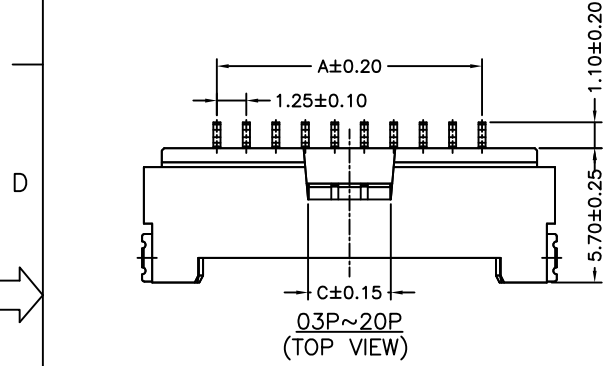
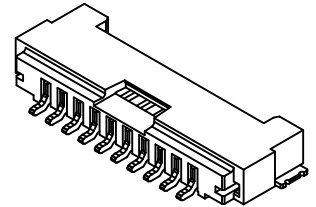
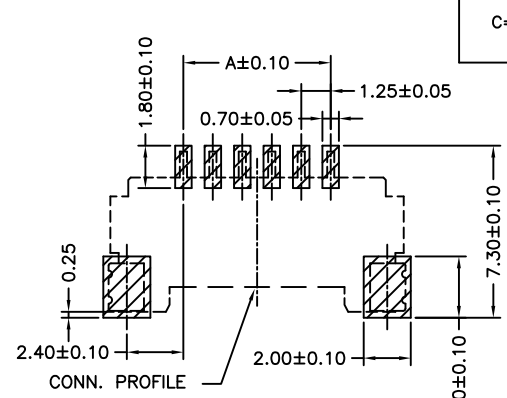

GENERAL TOLERANCE

X. X±0.25
X. XX±0.15
X. XXX±0.05

REV.	DESCRIPTION	DATE	NAME
B5	EN1708290002	2017.04.18	周傑亮
B4	EN1609220001	2016.09.22	周傑亮
B3	EN1105260153	2011.05.26	陳敏
B2	EN1012140291	2010.12.14	陳敏

Singatron Enterprise Co., Ltd.

TITLE	1.25mm PITCH 90° WAFER-SMT TYPE, ULTRA LOW PROFILE, WITHOUT BOSS		
DWN	歐陽小強	PART NO.	2WBA1253WRA-S-XP
CHKD	2007.12.26	SCALE 1:1	UNIT: mm
APVD	謝瑞清	SIZE: A3	SHEET: 1 OF 1 REV: B5

CUSTOMER COPY