

1

2

3

4

5

6

7

8

F

E

D

C

B

A

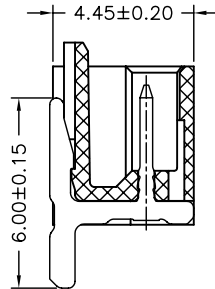
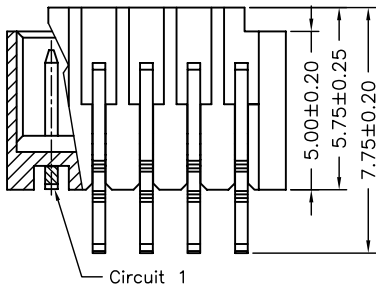
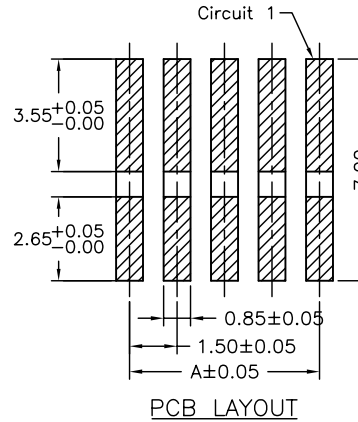
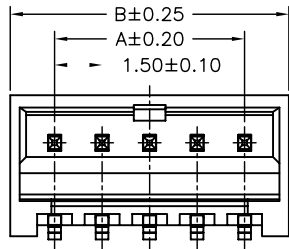
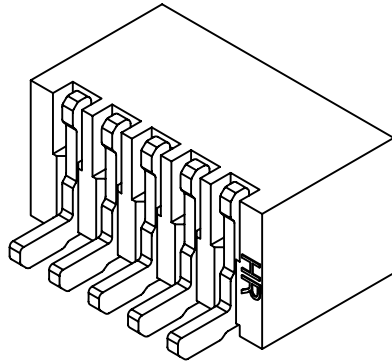

X. X±0.25  
X. XX±0.15  
X. XXX±0.05

REV.	DESCRIPTION	DATE	NAME
B3	EN1403100004	2014.02.14	周傑亮
B2	EN1312190439	2013.12.19	唐騰鳳
B1	REVISE	2006.04.13	蕭惠鳳
B0	NEW RELEASE	2006.04.13	蕭惠鳳

## P/N LEGEND

2WBA1501 WR-S-XP  
① ② ③ ④

- ① Series No.
- ② Connector type: WR=Right angle
- ③ Mounting type: S=SMT
- ④ No. of circuits

## SPECIFICATIONS

Current Rating: 3A AC,DC  
Voltage Rating: 350V AC,DC  
Temperature Range: -25°C ~ +85°C  
Contact Resistance: 20mΩ Max.  
Insulation Resistance: 1000MΩ Min.  
Withstanding Voltage: 500V AC/minute  
Pin Material: Brass/Tin-plated  
Material: Nylon 6T,UL94V-0  
Color: Natural(Beige)

PART NO.	Dimensions	
	A	B
02P	1.50	4.30
03P	3.00	5.80
04P	4.50	7.30
05P	6.00	8.80
06P	7.50	10.30
07P	9.00	11.80
08P	10.50	13.30
09P	12.00	14.80
10P	13.50	16.30
11P	15.00	17.80
12P	16.50	19.30
13P	18.00	20.80
14P	19.50	22.30
15P	21.00	23.80

Singatron Enterprise Co., Ltd.

TITLE	1.50mm PITCH 90° WAFER-SMT TYPE			
DWN	唐騰鳳	PART NO.2WBA1501WR-S-XP		
CHKD		SCALE 1:1	UNIT: mm	⊕ ↻
APVD	張子波	SIZE: A3	SHEET:1 OF 1	REV: B3
<b>CUSTOMER COPY</b>				