

SPECIFICATIONS
 Current Rating: 3A AC,DC
 Voltage Rating: 350V AC,DC
 Temperature Range: -25°C ~ +85°C
 Contact Resistance: 20mΩ Max.
 Insulation Resistance: 1000MΩ Min.
 Withstanding Voltage: 500V AC/minute
 Pin Material: Brass/Tin-plated
 Material: Nylon 6T,UL94V-0
 Color: Natural(Beige)

Ordering Information & Dimensions

PART NO.	Dimensions	
	A	B
2WBA1501WV-S-02P	1.50	4.30
2WBA1501WV-S-03P	3.00	5.80
2WBA1501WV-S-04P	4.50	7.30
2WBA1501WV-S-05P	6.00	8.80
2WBA1501WV-S-06P	7.50	10.30
2WBA1501WV-S-07P	9.00	11.80
2WBA1501WV-S-08P	10.50	13.30
2WBA1501WV-S-09P	12.00	14.80
2WBA1501WV-S-10P	13.50	16.30
2WBA1501WV-S-11P	15.00	17.80
2WBA1501WV-S-12P	16.50	19.30
2WBA1501WV-S-13P	18.00	20.80
2WBA1501WV-S-14P	19.50	22.30
2WBA1501WV-S-15P	21.00	23.80

Singatron Enterprise Co., Ltd.			
TITLE	1.50mm PITCH 180° WAFER-SMT TYPE		
DWN	董正一	PART NO.	2WBA1501WV-S-XXP
CHKD		SCALE	1:1 UNIT: mm
APVD	董正一	SIZE: A3	SHEET: 1 OF 1 REV: B1
CUSTOMER COPY			

X. X±0.25
 X. XX±0.15
 X. XXX±0.05

B1	REVISE	2006.09.10
B0	NEW RELEASE	2006.04.13
REV.	DESCRIPTION	DATE

02~09 Contacts

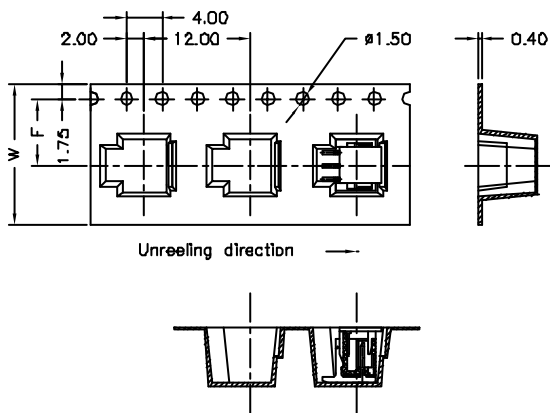

10~15 Contacts

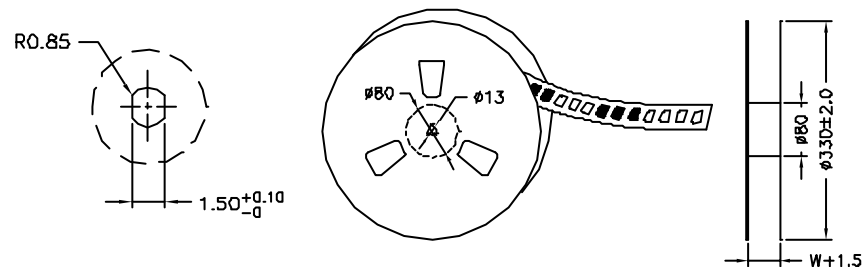
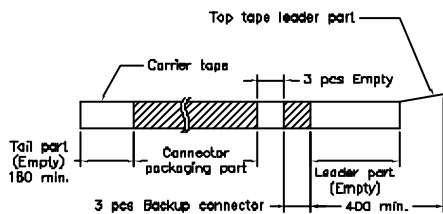
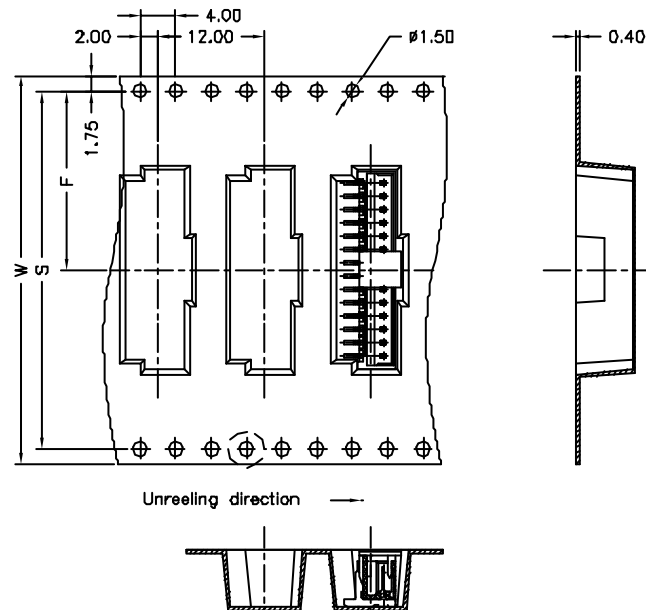

Number of Contacts	W±0.3	F±0.1	S±0.1	Q'ty/Reel
02P	16	7.50	/	500
03P	16	7.50		500
04P	16	7.50		500
05P	24	11.50		500
06P	24	11.50		500
07P	24	11.50		500
08P	24	11.50		500
09P	24	11.50		500
10P	32	14.20		28.40
11P	32	14.20	28.40	500
12P	32	14.20	28.40	500
13P	32	14.20	28.40	500
14P	44	20.20	40.40	500
15P	44	20.20	40.40	500

Singatron Enterprise Co., Ltd.

TITLE	1.50mm PITCH 180° WAFER-SMT TYPE TAPING SPEC.		
DWN	蕭惠鳳	PART NO.	2WBA1501WV-S--P
CHKD		SCALE	1:1 UNIT: mm
APVD	謝瑞清	SIZE: A3	SHEET: 1 OF 1 REV: B1

CUSTOMER COPY

B1	REVISE	2006.09.10
B0	NEW RELEASE	2006.04.13
REV.	DESCRIPTION	DATE