

P.C.B LAYOUT(TOP VIEW)

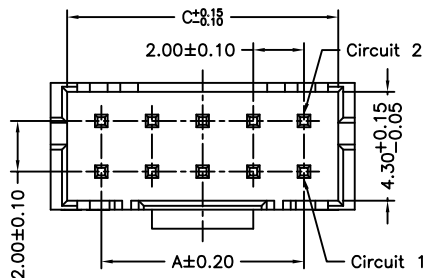

(TOP VIEW)

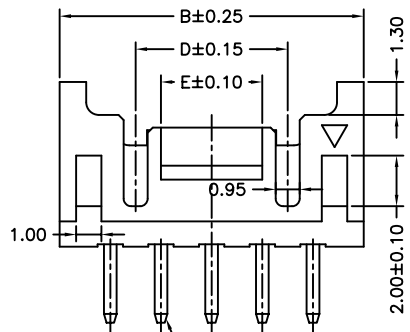

2X05~2X22P

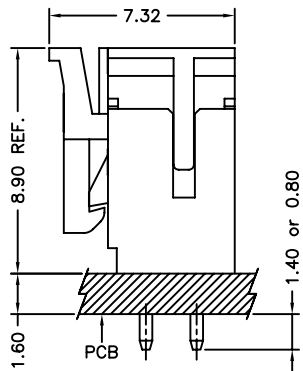

MATED CONDITION

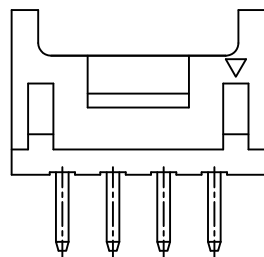

2X02~2X04P

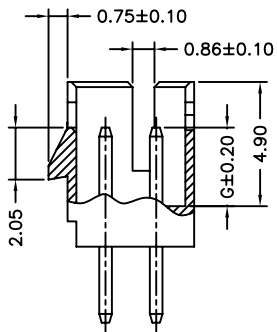
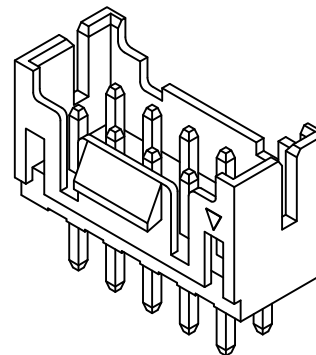

P/N LEGEND

<u>2WBA2004</u> <u>WVB-2XNP</u> <u>XXX</u>			
①	②	③	④
Series No.	Connector type: WVB=Vertical B Type	No. of circuits	Option code:
	Blank= DIM. F=3.00mm, G=3.10mm		Y01 = DIM. F=2.40mm, G=3.20mm

SPECIFICATIONS

Current Rating: 3A AC,DC
 Voltage Rating: 250V AC,DC
 Temperature Range: -25°C ~ +85°C
 Contact Resistance: 10mΩ Max.
 Insulation Resistance: 1000MΩ Min.
 Withstanding Voltage: 800V AC/minute
 Pin Material: Brass/Tin-plated
 Material: Nylon 66,UL94V-0
 Color: Natural(White)

Circuit No.	Dimensions				
	A	B	C	D	E
2X02P	2.00	6.00	4.70	---	1.50
2X03P	4.00	8.00	6.70	---	3.00
2X04P	6.00	10.00	8.70	---	4.00
2X05P	8.00	12.00	10.70	6.00	4.00
2X06P	10.00	14.00	12.70	8.00	4.00
2X07P	12.00	16.00	14.70	10.00	5.00
2X08P	14.00	18.00	16.70	12.00	5.00
2X09P	16.00	20.00	18.70	14.00	5.00
2X10P	18.00	22.00	20.70	16.00	5.00
2X11P	20.00	24.00	22.70	18.00	5.00
2X12P	22.00	26.00	24.70	20.00	5.00
2X13P	24.00	28.00	26.70	22.00	5.00
2X14P	26.00	30.00	28.70	24.00	5.00
2X15P	28.00	32.00	30.70	26.00	5.00
2X16P	30.00	34.00	32.70	28.00	5.00
2X17P	32.00	36.00	34.70	30.00	5.00
2X18P	34.00	38.00	36.70	32.00	5.00
2X19P	36.00	40.00	38.70	34.00	5.00
2X20P	38.00	42.00	40.70	36.00	5.00
2X21P	40.00	44.00	42.70	38.00	5.00
2X22P	42.00	46.00	44.70	40.00	5.00

Singatron Enterprise Co., Ltd.

TITLE	2.00mm PITCH180° WAFER		
DWN	規格/標準 2008.01.08	PART NO.2WBA2004WVB-2XNPXXX	
CHKD	SCALE 1:1	UNIT: mm	⊕ ↻
APVD	規格/標準 2008.01.08	SIZE: A3	SHEET:1 OF 1 REV: A5

CUSTOMER COPY

				GENERAL TOLERANCE	
				X. X±0.25	ANGLE±
A5	EN1109290442	2011.10.06	陳錦展	X. XX±0.15	
REV.	DESCRIPTION	DATE	NAME	X. XXX±0.05	⊕ ⊗