

PCB Layout

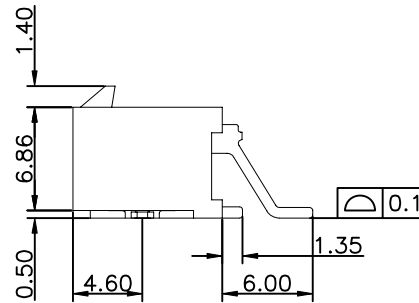
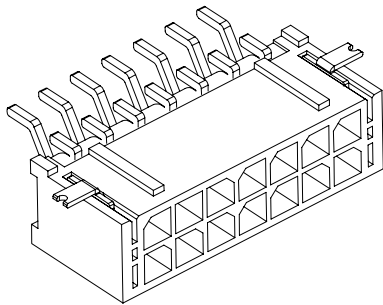
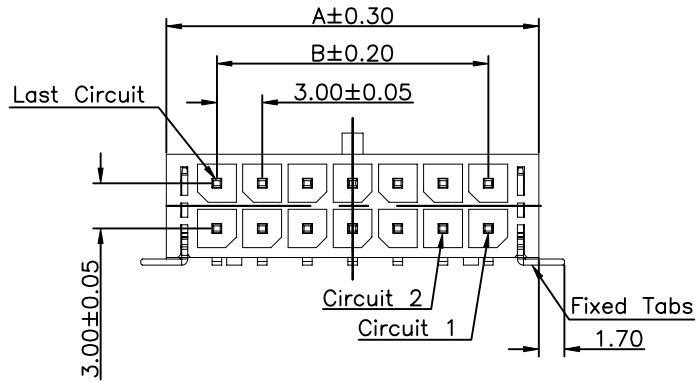

P/N LEGEND

2WBC3030	WRA-S-2XNP	N 9	B T1	T 00	R
①	②	③	④	⑤	⑥
⑦	⑧	⑨	⑩	⑪	⑫

① Series No.
 ② Connector type: WRA=Right angle A Type
 ③ Mounting type: S=SMT without post
 ④ No. of circuits
 ⑤ N=Halogen Free
 ⑥ Material: 9=PA9T,UL94V-0
 ⑦ Color: B=Black
 ⑧ Plating code for contacts:
 T1=Matte Tin-plated
 ⑨ Plating code for solder tabs:
 T=Matte Tin-plated
 ⑩ Option code: 00=Standard
 ⑪ Packing code:
 R=Tape & Reel(Without Cap or Mylar)

SPECIFICATIONS

Current Rating: 5A AC,DC
 Voltage Rating: 250V AC,DC
 Temperature Range: -25°C ~ +105°C
 Contact Resistance: 10mΩ Max
 Insulation Resistance: 1000MΩ Min
 Withstanding Voltage: 1500V AC/minute
 Pin Material: Copper Alloy / Matte Tin-plated
 Material: PA9T,UL94V-0
 Color: Black

Circuit No.	Dimensions		Circuit No.	Dimensions	
	A	B		A	B
2X01P	6.7	---	2X07P	24.7	18.00
2X02P	9.7	3.00	2X08P	27.7	21.00
2X03P	12.7	6.00	2X09P	30.7	24.00
2X04P	15.7	9.00	2X10P	33.7	27.00
2X05P	18.7	12.00	2X11P	36.7	30.00
2X06P	21.7	15.00	2X12P	39.7	33.00

Singatron Enterprise Co., Ltd.

TITLE	3.0mm PITCH 90° WAFER-SMT DUAL ROW TYPE		
DWN	郭木思	PART NO.	2WBC3030WRA-S-2XNPXXXXXXXXXX
CHKD	2016.02.24	SCALE 1:1	UNIT: mm
APVD	陳彥兆	SIZE: A3	SHEET: 1 of 2
REV: A0			

REV.	DESCRIPTION	DATE	NAME	GENERAL TOLERANCE	ANGLE±
A0	NEW RELEASE	2016.02.24	郭木思	X.X±0.25	▽
				X.XX±0.15	▽
				X.XXX±0.05	▽

CUSTOMER COPY

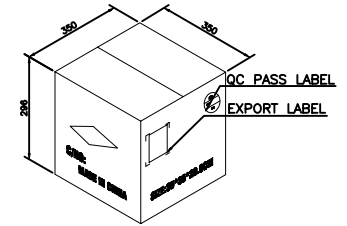
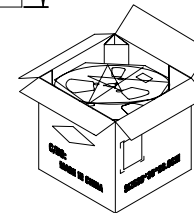
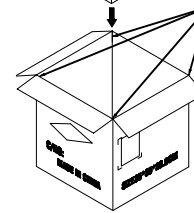
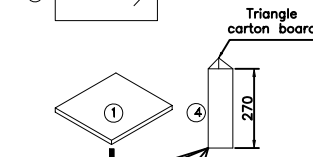
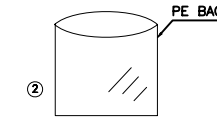
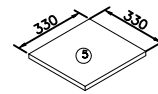
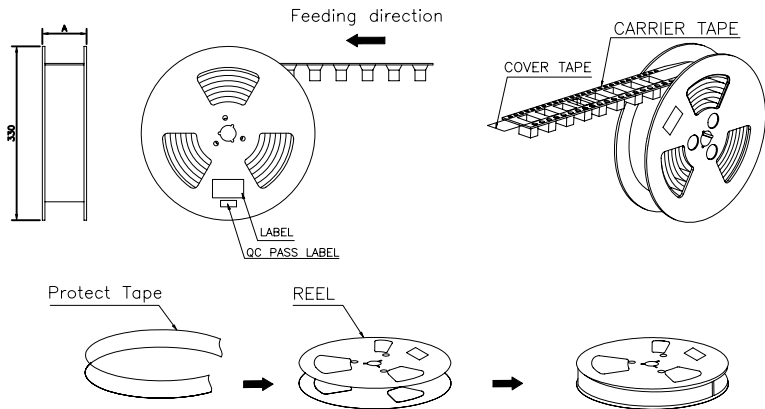
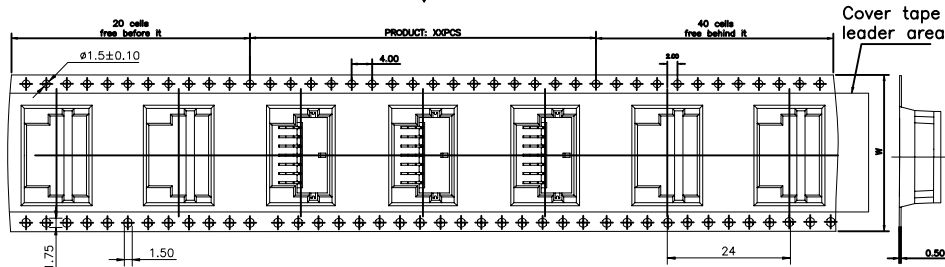
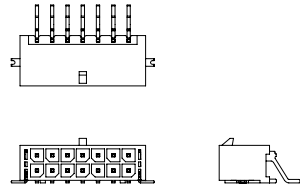

SPECIFICATIONS:

1.DIMENSION

- REEL SIZE: 330*AMM
- PE BAG SIZE: 0.8*710*720(MM)
- CARTON SIZE:350*350*296(MM)
- SET SPUAR SIZE:35*25.5*270(MM)
- NADIR COVER SIZE:330*330(MM)

2.QUANTITY:

- 200PCS/REEL
- XXREEL/ CARTON
- Q'TY: XXPCS

- 3.W ≤ 24mm, Single Row Hole.
- W > 24mm, Double Rows Hole.

Pin No	W	A	PCS/R	R/CTN	Q'TY
02	24	29	200	9	1800
04	24	29	200	9	1800
06	32	37	200	7	1400
08	44	49	200	5	1000
10	44	49	200	5	1000
12	44	49	200	5	1000
14	44	49	200	5	1000
16	44	49	200	5	1000
18	56	61	200	4	800
20	56	61	200	4	800
22	56	61	200	4	800
24	56	61	200	4	800

Singatron Enterprise Co., Ltd.

TITLE	3.0mm PITCH 90° WAFER-SMT DUAL ROW TYPE			
DWN	郭木思	PART NO.	2WBC3030WRA-S-2XNPNXXXXXXXXX	
CHKD	2016.02.24	SCALE	1:1	UNIT: mm
APVD	陳彥兆	SIZE	A3	SHEET: 1 of 2

CUSTOMER COPY

				GENERAL TOLERANCE	
				X. X±0.25	ANGLE±
A0	NEW RELEASE	2016.02.24	郭木思	X. XX±0.15	
REV.	DESCRIPTION	DATE	NAME	X. XXX±0.05	