

1 2 3 4 5 6 7 8

F

E

D

C

B

A

F

E

D

C

B

A

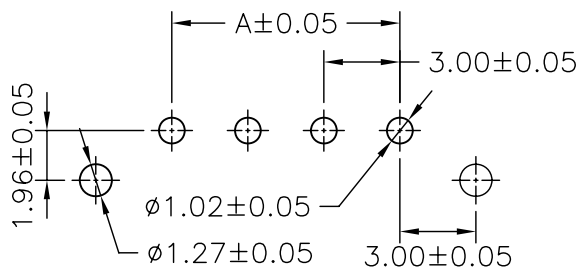
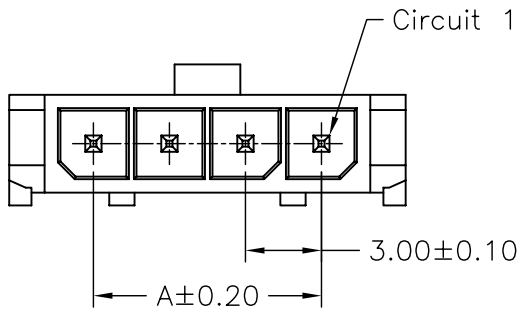

P.C.B. LAYOUT

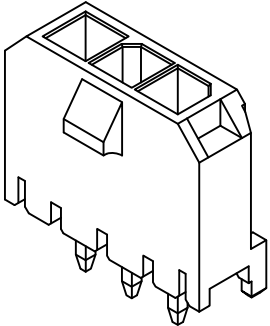
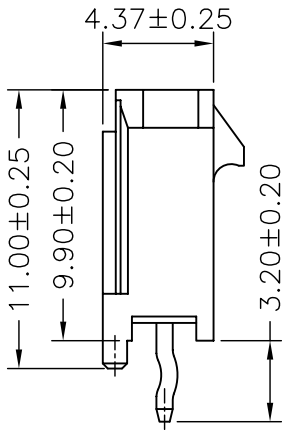
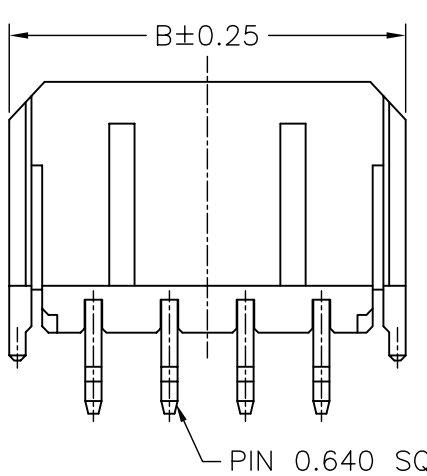

P/N LEGEND

<u>2</u>	<u>W</u>	<u>-</u>	<u>F</u>	<u>-</u>	<u>X</u>	<u>P</u>	<u>X</u>	<u>T</u>	<u>N</u>	<u>00</u>	<u>B</u>
①	②	③	④	⑤	⑥	⑦	⑧	⑨	⑩	⑪	

① Series No.
 ② Connector type: WV=Vertical
 ③ F=With boss or peg
 ④ No. of circuits
 ⑤ R=Rohs
 ⑥ Material: P=PBT
 ⑦ Color: W=White; R=Red
 ⑧ Plating code for contacts: T1=Tin-plated
 ⑨ Plating code: N=Non-plating
 ⑩ Option code:
 00=Standard
 ⑪ Packing code:B=Tray

SPECIFICATIONS

Current Rating: 5A AC,DC
 Voltage Rating: 250V AC,DC
 Temperature Range: -25°C ~ +85°C
 Contact Resistance: 10mΩ Max
 Insulation Resistance: 1000MΩ Min
 Withstanding Voltage: 1500V AC/minute
 Pin Material: Brass/Tin-plated
 Material: PBT15%GF,UL94V-0
 Color: White or Red

Circuit No.	Dimensions		Circuit No.	Dimensions	
	A	B		A	B
02P	3.00	9.65	10P	27.00	33.65
03P	6.00	12.65	11P	30.00	36.65
04P	9.00	15.65	12P	33.00	39.65
05P	12.00	18.65			
06P	15.00	21.65			
07P	18.00	24.65			
08P	21.00	27.65			
09P	24.00	30.65			

Singatron Enterprise Co., Ltd.					
TITLE	3.00mm PITCH 180° WAFER, SINGLE ROW, MICRO-FIT				
DWN	劉包根	PART NO.	2WBC3030WV-F-XPRXXXXXXXXX		
CHKD	2012.05.15	SCALE	1:1	UNIT:	mm
APVD	董正一	SIZE:	A3	SHEET:	1 OF 1
				REV:	A1
CUSTOMER COPY					

REV.	DESCRIPTION	DATE	NAME	GENERAL TOLERANCE	ANGLE±
A1	EN1409020004	2014.09.02	郭木思	X.X±0.25	ANGLE±
A0	NEW RELEASE	2012.05.15	劉包根	X.XX±0.15	
				X.XXX±0.05	

1 2 3 4 5 6 7 8