

- SPECIFICATIONS
- Current Rating : 5A AC/DC
 - Withstanding Voltage : 1,000V AC/minute
 - Insulation Resistance : 1,000M Ω min.
 - Temperature Range : - 40°C to + 105°C
 - Contact Resistance : 20m Ω max.

- TERMINAL
- Part No. : 2WT1102-TXX(L)
- ① Blank: Standard Plated Process
P: Stamping Before Plated
H : High Crimp, Brass
HP : Stamping before Plated, High Crimp, Brass
- Material : Brass T=0.25mm
 - Finished:
 - △ JS-1102-T(L): 80u" min. TIN over 15u" min. NICKEL
 - △ JS-1102-TP(L): 120u" min. TIN over 30u" min. NICKEL
 - △ JS-1102-TH(L): 80u" min. TIN over 15u" min. NICKEL
 - △ JS-1102-THP(L): 120u" min. TIN over 30u" min. NICKEL
- Applicable Wires :
 - 1. Standard: AWG#18~22
 - 2. High Crimp: AWG#16~20
 - Q'TY: 6,000PCS/Reel

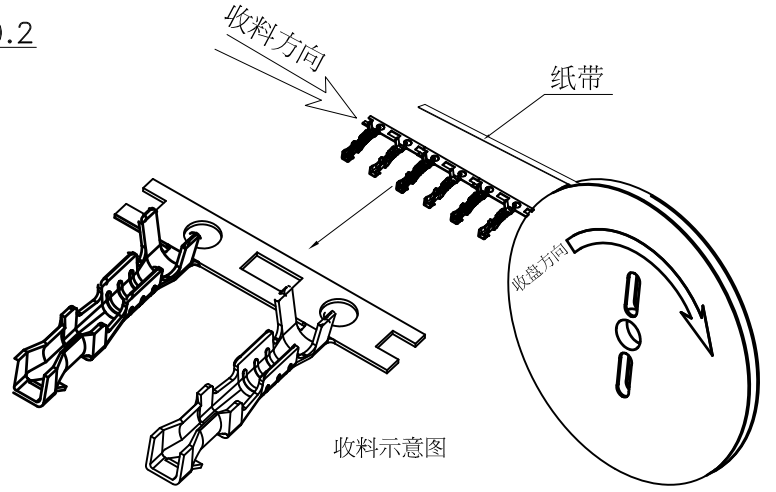
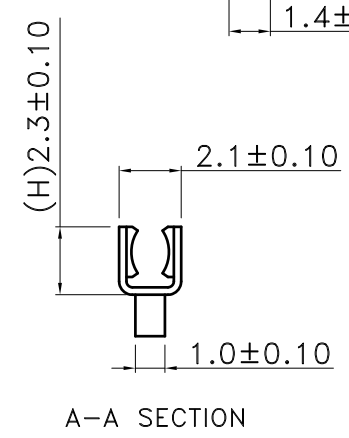
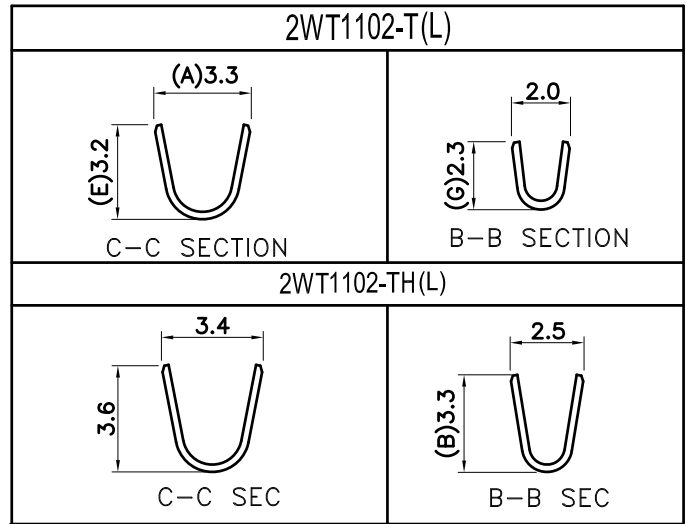

TOLERANCE	LTR	REVISION RECORD	NAME	DATE	LTR	REVISION RECORD	NAME	DATE
.0	±0.30	删除GP料號	吳弘文	2013/05/24				
.00	±0.20	增加高腳機種	邱建輝	2014/02/21				
.000	±0.10							
ANGLE								
0°	±1°							
.0°	±							
SHEET	1/1							

Singatron Enterprise Co., Ltd.

TITLE	5.00mm Crimp Style Connectors Terminal			
DWN	邱建輝	PART NO.	2WT1102-TXX(L)	
CHKD	黃科源	SCALE	1:1	UNIT: mm
APVD	張育瑞	SIZE	A3	SHEET: 1 OF 1 REV: a2
CUSTOMER COPY				

CUSTOMER

Conforms to The RoHS Instruction