

1 2 3 4 5 6 7 8

F

E

D

C

B

A

REV	ECN.NO.	REVISIONS	REV.DRAWN	DATE
C		更改料号	YU	06-12/20
D	08073	卡勾结构变更	Yuqilong	08-07/18
E		更正料号	sunquan	12-01/09
F		增加尺寸标注	sunquan	12-08/13

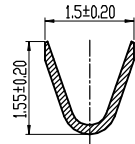

SECTION Z-Z

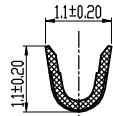

SECTION A-A

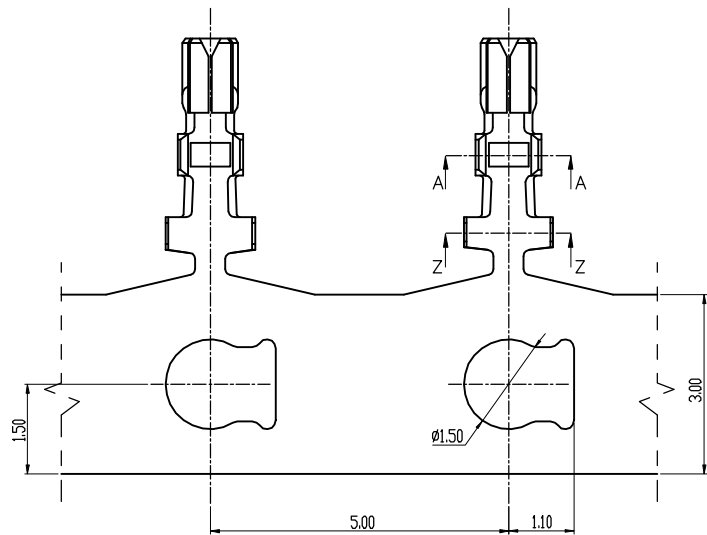
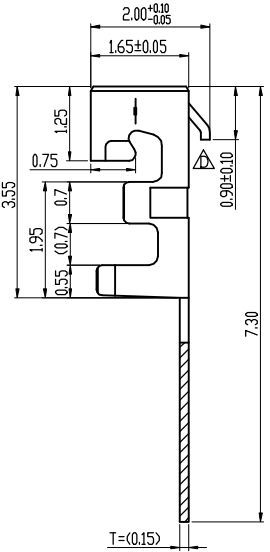
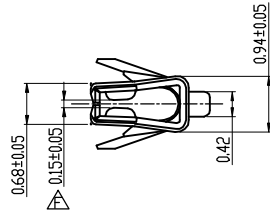

SPECIFICATIONS

- . Voltage Rating : 150V AC/DC
- . Current Rating : 1A AC/DC
- . Withstanding Voltage : 250V AC/minute
- . Insulation Resistance : 100MΩ min
- . Temperature Range : -40°C to +85°C
- . Contact Resistance : 20mΩ max

TERMINAL

- . Part No : **2WT2255-TG1**
- . Material : Phos.bronze,Gold Plated
- . Applicable Wires : AWG#28-32
- . Thickness : 0.15mm
- . Q'ty : 15,000pcs/Reel

X.± 0.40	X'.± 5.0'	Singatron Enterprise Co., Ltd.			
.X± 0.30	.X'.± 2.0'				
.XX± 0.20	.XX'.± 1.0'	TITLE	1.25 DUAL WIRE TO BOARD CONN TERMINAL		
.XXX± 0.10	.XXX'.± ---	DWN	Yuqilong 08-07/17	PART NO. 2WT2255-TG1	
		CHKD	SCALE 1:1	UNIT: mm	⊕ ↗
		APVD	SIZE: A3	SHEET: 1 OF 1	REV: F
CUSTOMER COPY					

1 2 3 4 5 6 7 8