

REV	ECN.NO.	REVISIONS	REV.DRAWN	DATE
B		增加PIN位	CARRY	08-05/2
C		增加无卤料号说明	Yuqilong	2008/11/1
D		修改料号编码	sunquan	2010/10/2
E		整理图面, 料号	sunquan	2011/08/0

HOUSING

- Part No: 2WW2420-2xXX-XXXX-NH
- Poles: 2X02~2X04
- Blank: PA66
- D1: PA66(G.F.)
- Material: PA66, UL94V-0
- Q'ty: 1,000pcs/Bag
- Halogen free product identification LOGO on the packing

Blank: Normal  
NH: Halogen Free  
Blank: Nature

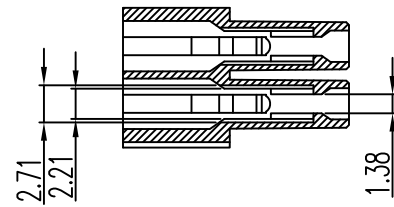
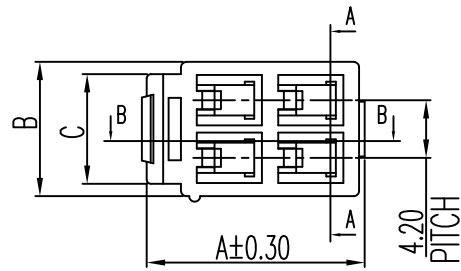

SECTION A-A

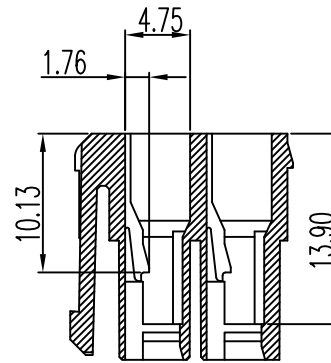
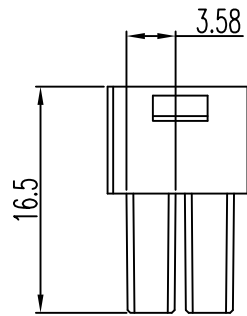
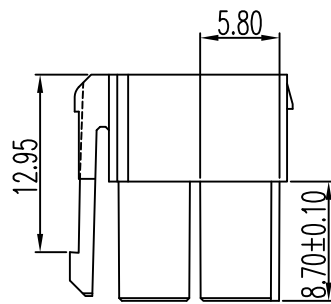

SECTION B-B

2X04	15.90	18.20	9.80
2X03	15.90	14.00	9.80
2X02	15.90	9.80	8.00
POLE NO.	A	B	C

Singatron Enterprise Co., Ltd.

X.± 0.40	X°.± 5.0°	TITLE	4.20mm Crimp Style Connector		
.X± 0.30	.X°.± 2.0°	DWN	Yuqilong	PART NO. 2WW2420-2xXX-XXXX-NH	
.XX± 0.20	.XX°.± 1.0°	CHKD	2011/08/01	SCALE 1:1	UNIT: mm
.XXX± 0.10	.XXX°.± ---	APVD	liuzhiwen	SIZE: A3	SHEET: 1 OF 1
<b>CUSTOMER COPY</b>					
		REV:	E		