

REV.	ECN NO OR DESCRIPTION	REVISED	DATE
T	PDR NO.20070124-2-S	LULU	2007.03.20
A	PDR RELEASE	LULU	2007.03.23

- SPECIFICATION
- 1.TO CONFORM TO THE "SE-01-001" & "ROHS DIRECTIVE"
 - 2.GREEN PRODUCT IDENTIFICATION LABEL IN PACKING: **G.P. PASS**
 - 3.SOLDER HEAT RESISTANCE : 260°C 10 SECS.
 - 4.SEE "2BA-902A-001" SPEC.
 - 5.PACKAGE : TAPE&REEL.

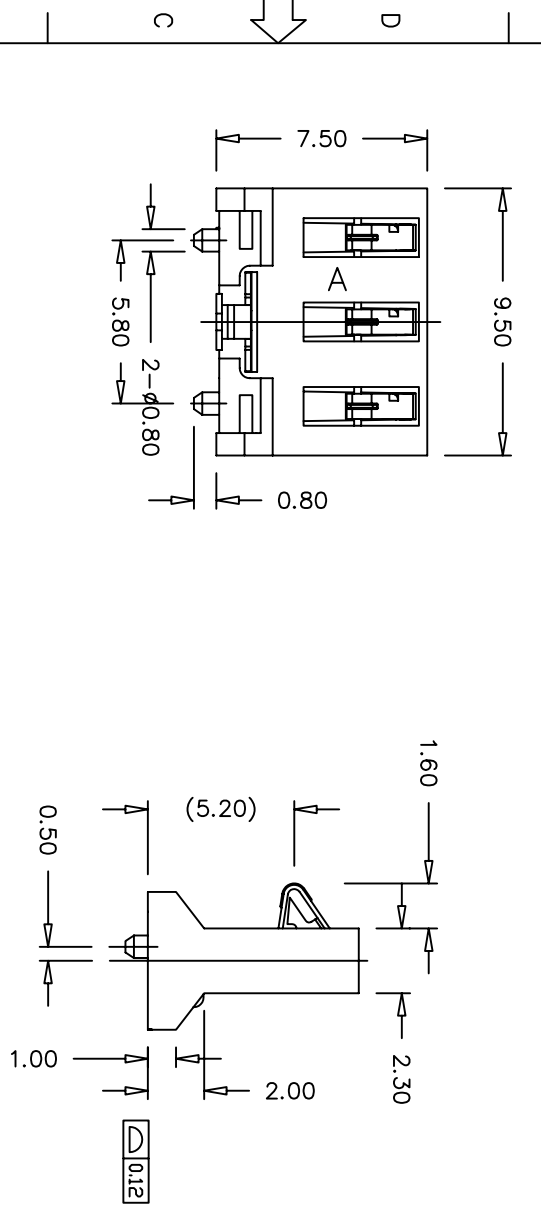
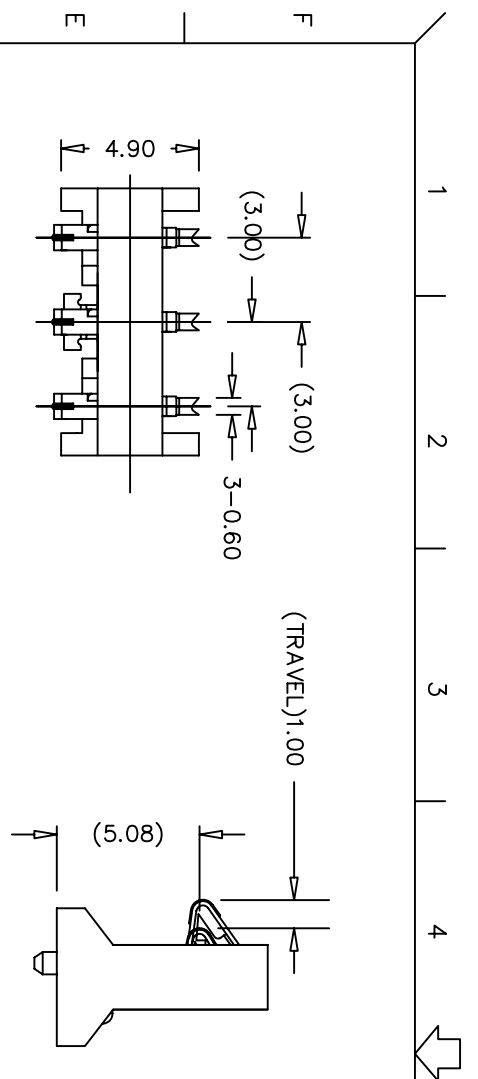

RECOMMENDED PADS LAYOUT

<TOP VIEW>

NOTE : TOLERANCE FOR PCB LAYOUT IS ± 0.05

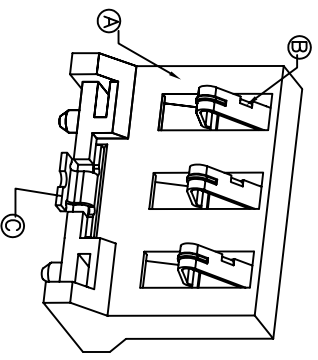
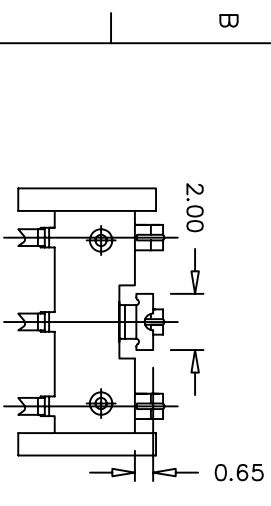
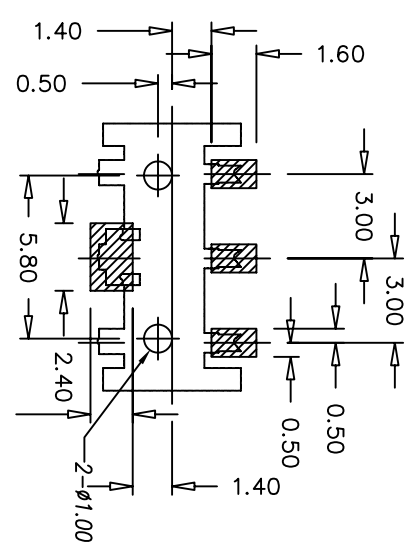

NO	DESCRIPTION	QTY	MATERIAL	PLATING & COLOR
C	PAD	1	COPPER ALLOY	TIN PLATING
B	BATTERY CONTACT	3	COPPER ALLOY	GOLD PLATING
A	HOUSING	1	HIGH TEMPERATURE THERMOPLASTIC UL94V-0	BLACK COLOR

UNLESS OTHERWISE SPECIFIED TOLERANCES



Singatron Enterprise Co., Ltd.
信晉企業股份有限公司

TITLE	BATTERY SOCKET / 3 POS
DWN	LULU 2007.03.20 PART NO.2BA-902A-001
CHKD	REN 2007.03.20 SCALE:3/1 UNIT: mm
APVD	ANGLIA 2007.03.20 SIZE: A3 SHEET: 10F1

CUSTOMER COPY