

RECOMMENDED P.C.B. LAYOUT  
TOP VIEW (TOLERANCE: ±0.05)

SPECIFICATIONS:

1. RATINGS
  - 1-1. VOLTAGE: AC 50V
  - 1-2. CURRENT: 5.0A
  - 1-3. OPERATING TEMPERATURE: -40°C~105°C.
  - 1-4. STORAGE TEMPERATURE: -40°C~105°C.
2. TO CONFORM TO THE SINGATRON HSF SPECIFICATION.
3. HALOGEN FREE PRODUCT IDENTIFICATION MARK:
4. HALOGEN FREE PRODUCT IDENTIFICATION LABEL ON PACKAGING:
5. FOR LEAD-FREE PROCESS.
6. PACKAGING IN Tape & Reel.
7. PRINTED DATE CODE "YYMMDD" ON TOP OF CONNECTOR.

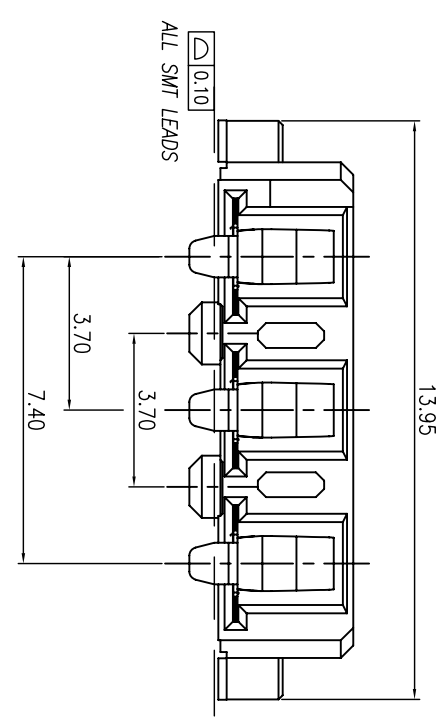
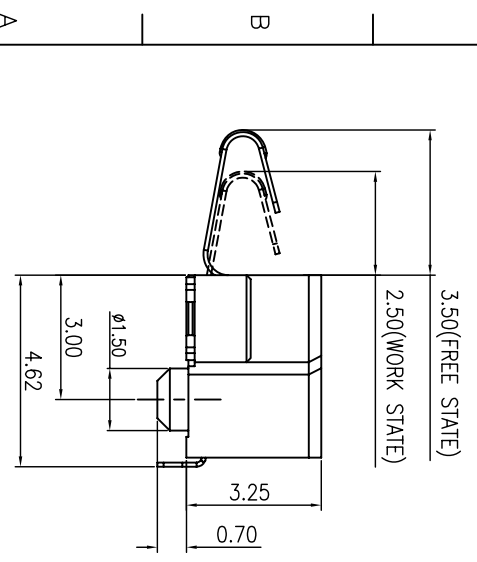
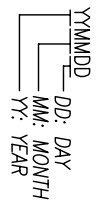

C	TAB	2	COPPER ALLOYL.0.20T	TIN OVER NICKEL
B	CONTACT	3	COPPER ALLOYL.0.10T	GOLD ON CONTACT AREA
A	HOUSING	1	HI-TEMP THERMOPLASTIC UL94V-0	COLOR BLACK
NO	DESCRIPTION	QTY	MATERIAL	PLATING & COLOR

UNLESS OTHERWISE SPECIFIED TOLERANCES

DECIMALS:	ANGLES:
X :±0.5	X :±2°
X.X :±0.3	X.X :±1°
X.XX :±0.2	

DWN	Steve-hui 090418	PART NO. 2BA2006-000111
CHKD	Muyron 090418	SCALE 8:1 UNIT: mm
APVD	Robin 090418	SIZE: A3 SHEET: 10F1

CUSTOMER COPY

REV.	ECN NO OR DESCRIPTION	REVISED	DATE
A	INITIAL RELEASE	Steve-hui	2009.04.15