

REV.	ECN NO. OR DESCRIPTION	REVISED	DATE
A	NEW RELEASE	G100	2007.11.05

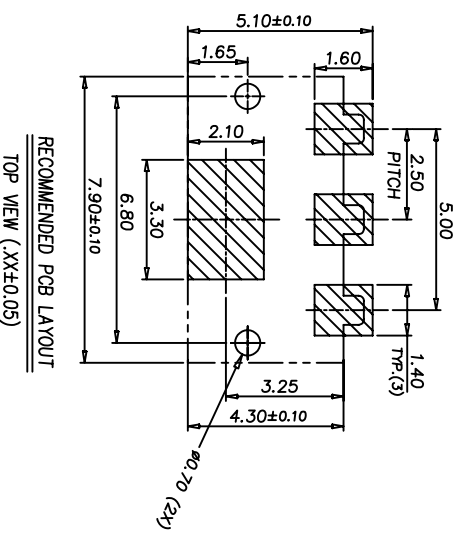
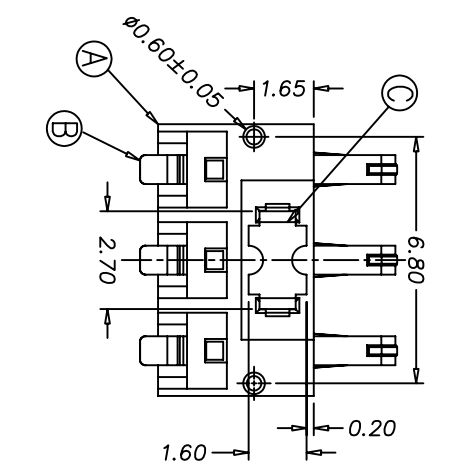
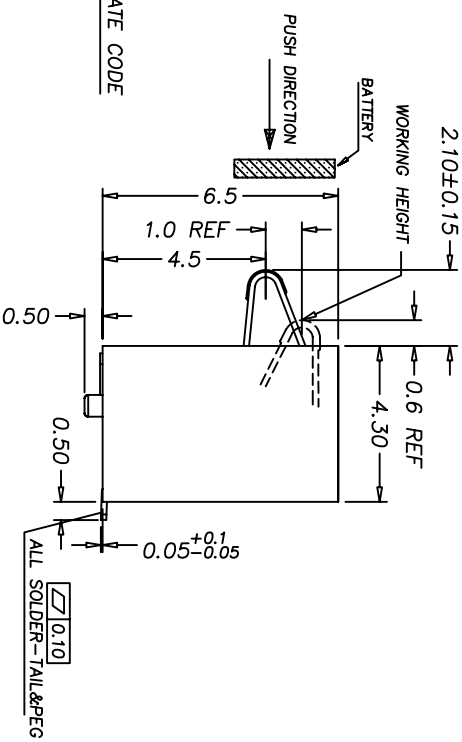
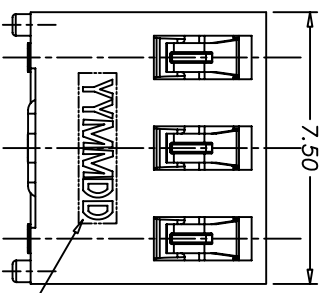
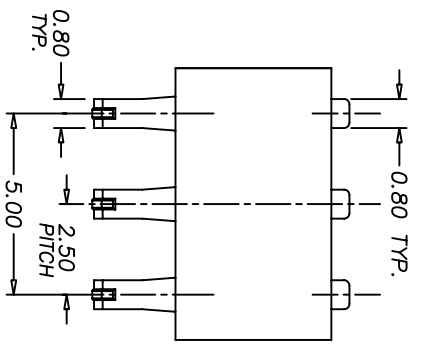
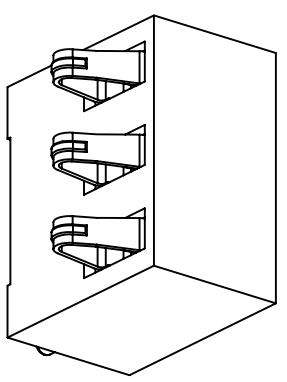

- NOTES:
- CURRENT RATING : 2A MIN.
  - CONTACT RESISTANCE: 30 MILLI OHM MAX.
  - DIELECTRIC WITHSTANDING VOLTAGE : 250V AC MIN.
  - FOR ONE MINUTE:
  - INSULATION RESISTANCE : 500 MΩ MIN.
  - OPERATING TEMPERATURE : -55°C TO +85°C.
  - NORMAL FORCE : 80g MIN(WORKING POSITION)
  - DURABILITY: 5,000 CYCLES
  - SOLDER HEAT RESISTANCE: REFLOW SOLDERING 260°C 10 SECS.
  - PARTS TO BE PACKAGED IN TAPE AND REEL
  - TO CONFORM TO THE "SE-01-001" & "ROHS DIRECTIVE"
  - GREEN PRODUCT IDENTIFICATION MARK IN BODY:
  - GREEN PRODUCT IDENTIFICATION LABEL IN PACKING:
  - PRINTED DATE CODE "YYMMDD" ON FRONT OF CONNECTOR.

C	PAD	1	COPPER ALLOY 0.2T	120u" Sn UNDERPLATING, 50U" Ni
B	CONTACT	3	COPPER ALLOY 0.15T	15U" Au ON CONTACT AREA GOLD FLASH ALL OVER Ni UNDERPLATING ALL OVER
A	BODY	1	THERMOPLASTIC, UL 94V-0	BLACK COLOR
NO	DESCRIPTION	QTY	MATERIAL	PLATING & COLOR
UNLESS OTHERWISE SPECIFIED TOLERANCES				
Singatron Enterprise Co., Ltd. 信登企業股份有限公司				
TITLE 3 PIN BATTERY CONNECTOR (WITH POST)				
DWG (300) 20071105 PART NO. 2BA3014-365111				
CHKD (LSSN) 20071105 SCALE:N/A UNIT: mm				
APVD (SMD) 20071105 SIZE: A3 SHEET: 1 OF 1 REV: A				
CUSTOMER COPY(SZ)				

1 2 3 4 5 6 7 8

X# 06-035-1A