

REV.	ECN NO OR DESCRIPTION	REVISED	DATE
A	PDR NO.S100413	BRUCE	2010.08.23

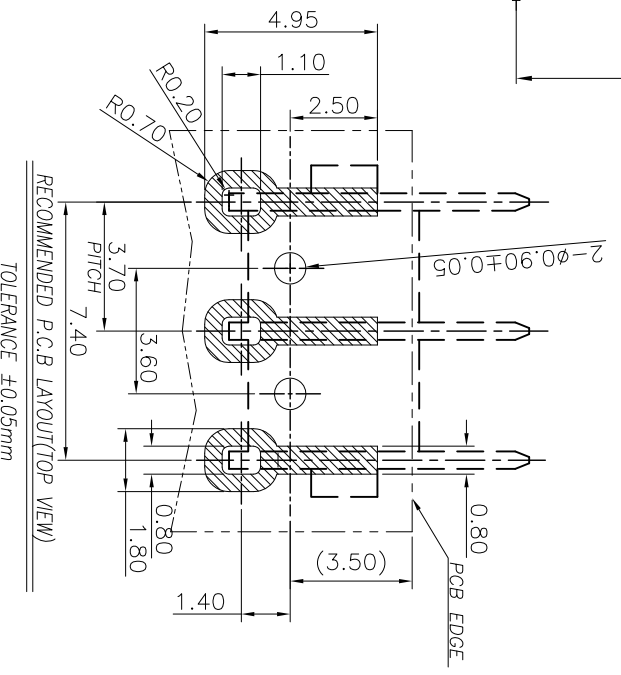
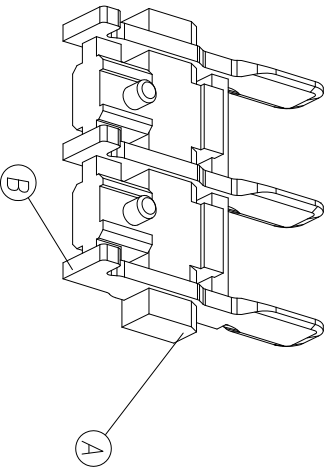
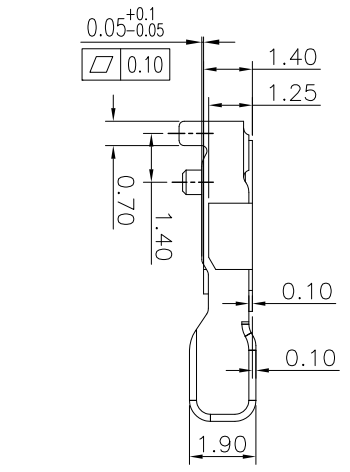
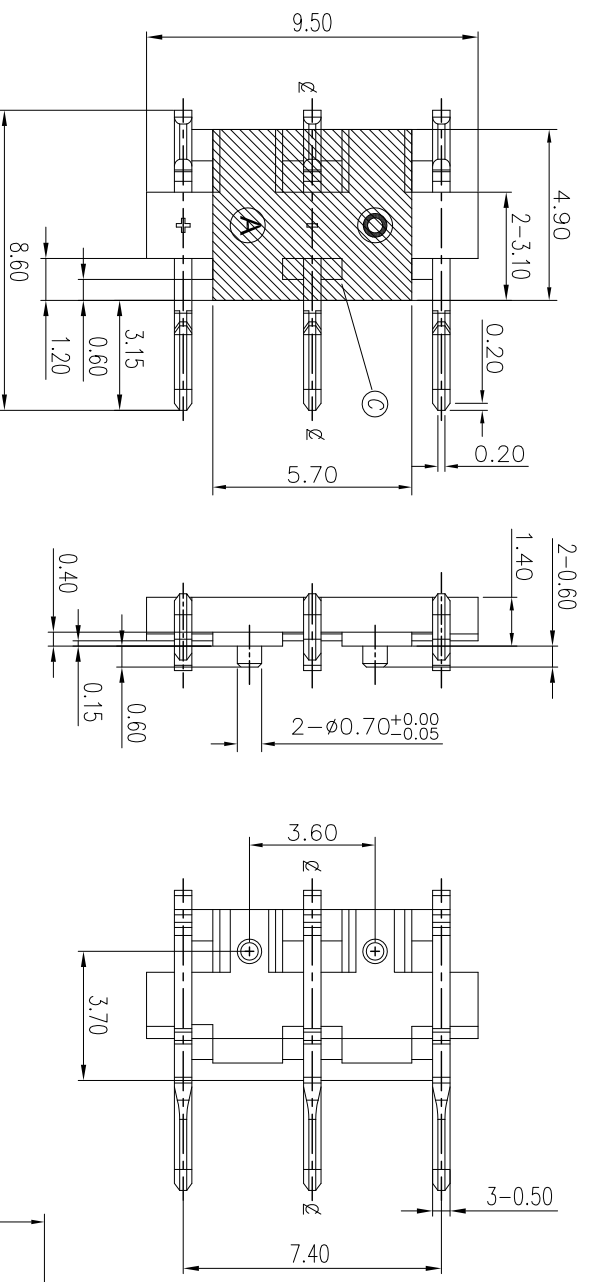

- SPECIFICATIONS:**
- ELECTRICAL CHARACTERISTICS:**
 - 1-1. DIELECTRIC WITHSTANDING VOLTAGE: 500V AC FOR ONE MINUTE
 - 1-2. INSULATION RESISTANCE: 100MΩ MIN. MEASURED BY 500 VDC
 2. TO CONFORM TO SINGATRON HAZARDOUS SUBSTANCE FREE SPEC.
 3. HALOGEN FREE PRODUCT IDENTIFICATION MARK ON JACK:
 4. HALOGEN FREE PRODUCT IDENTIFICATION LABEL ON PACKAGING:
 5. FOR REFLOW SOLDERING LEAD-FREE PROCESS.

C	MYLAR	1	W4.9*5.7*10.07	YELLOW
B	CONTACT TERMINAL	3	COPPER ALLOY 0.5T	GOLD FLASH OVER N: 50U*
A	BODY	1	HIGH THERMOPLASTIC TEMP. UL 94V-0	BLACK
NO	DESCRIPTION	QTY	MATERIAL	PLATING & COLOR
UNLESS OTHERWISE SPECIFIED TOLERANCES				
Singatron Enterprise Co., Ltd. 信音 企業 股份 有限 公司				
DECIMALS: ANGLES:				
X	:±0.50	X	:±2°	
X.X	:±0.30	X.X	:±1'	
X.XX	:±0.20			
TITLE: 3 PIN BATTERY CONNECTOR				
DWN	Brugg 2010.08.26	PART NO.: 2BA3022-003111		
CHKD	Boys 2010.08.26	SCALE: 4:1 UNIT: mm		
APVD	Mod 2010.08.26	SIZE: A3 SHEET: 1 OF 1 REV: A		
CUSTOMER COPY				

1 2 3 4 5 6 7 8