

REV.	ECN NO OR DESCRIPTION	REVISED	DATE
A	PDR NO.T130830-2A	Dak	2014.01.17

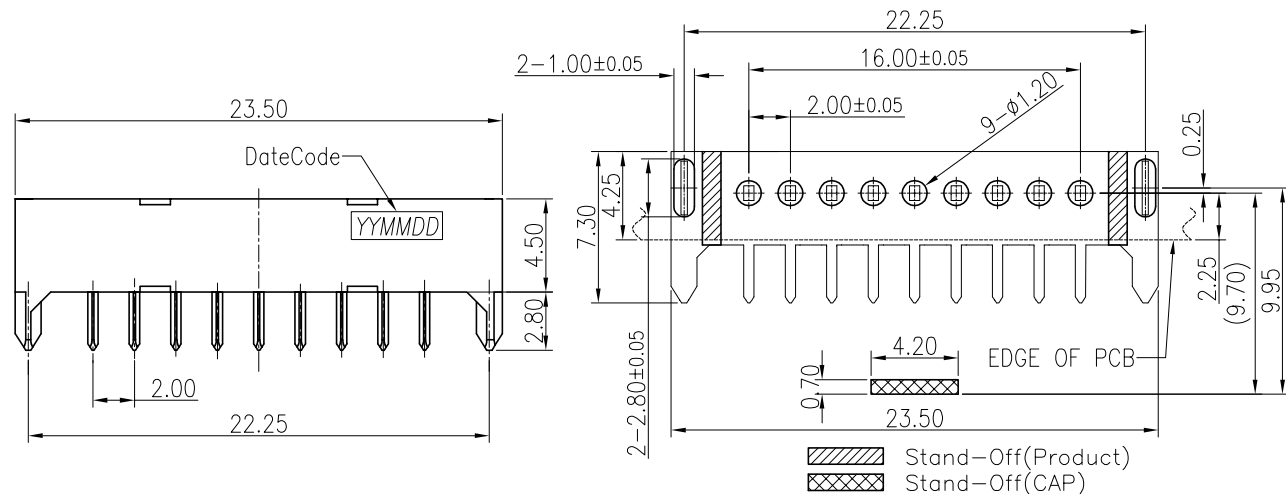

SPECIFICATIONS:

- ELECTRICAL CHARACTERISTICS
 - CURRENT RATING: 3.0AMP MAX PER CONTACT.
 - VOLTAGE RATING: 240V DC
 - CONTACT RESISTANCE: 20m Ohm MAX.
 - DIELECTRIC WITHSTANDING VOLTAGE: 500V AC FOR 1 MINUTE
 - INSULATION RESISTANCE: 1000M Ohm MIN.
- MECHANICAL CHARACTERISTICS
 - DURABILITY: 5,000 CYCLES.
- ENVIRONMENT CHARACTERISTICS
 - STORAGE TEMPERATURE: -40° TO +85°.
 - OPERATION TEMPERATURE: -55° TO +105°.
- TO CONFORM TO SINGATRON HAZARDOUS SUBSTANCE FREE SPEC.
- HALOGEN PRODUCT IDENTIFICATION LABEL ON PACKAGING
- FOR REFLOW SOLDERING LEAD-FREE PROCESS.

RECOMMENDED PCB LAYOUT (TOP VIEW)

GENERAL TOLERANCES: ±0.05 (t=1.2)

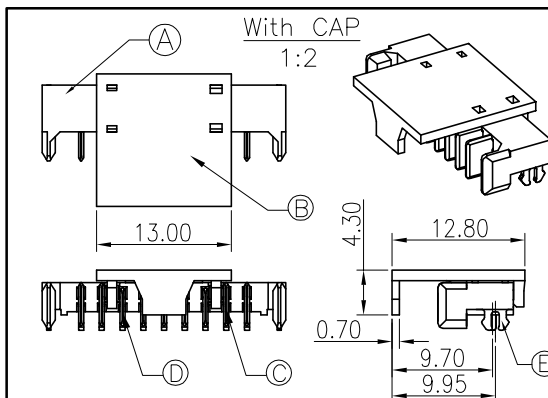
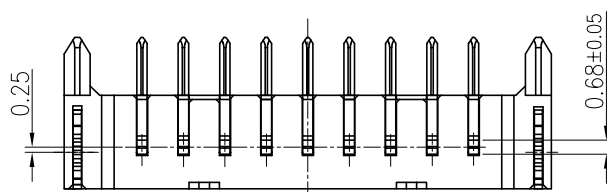
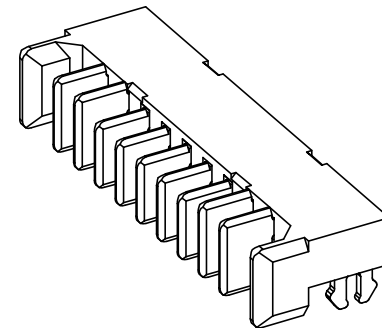
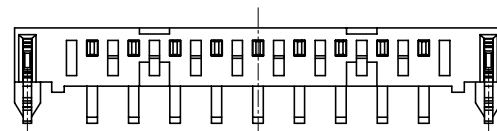
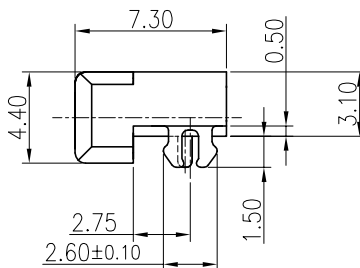
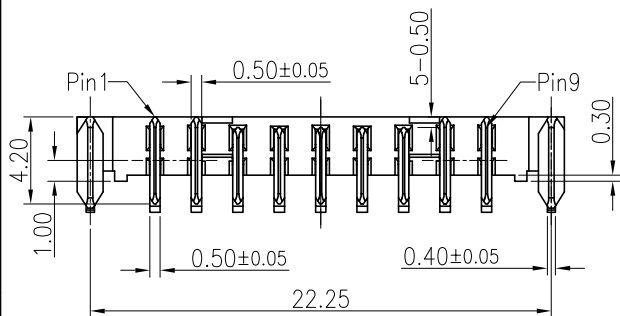

E	FORK	1	Brass 0.3T	Matt-Tin 100u" MIN PLATED ALL OVER
D	CONTACT-S	5	Brass 0.5T	G/E ON CONTACT AREA
C	CONTACT-B	4		MATT-TIN 100u" MIN ON SOLDER AREA
B	CAP	1	LCP+30%G.F	UL94V-0 BLACK
A	HOUSING	1	LCP+30%G.F	UL94V-0 BLACK
NO	DESCRIPTION	QTY	MATERIAL	PLATING & COLOR

UNLESS OTHERWISE SPECIFIED TOLERANCES

DECIMALS: ANGLES:
 X :±0.5 X :±2°
 X.X :±0.3 X.X :±1°
 X.XX :±0.2

Singatron Enterprise Co., Ltd.
 信音企業股份有限公司

TITLE	BATTERY 9Pin PLUG. DIP Type.CH=1.0mm		
DWN	Dak	PART NO.2BA3Y11-009411F	
CHKD	SCALE N/A	UNIT: mm	
APVD	BOYE	SIZE: A3	SHEET: 10F1 REV:A

CUSTOMER COPY