

REV	ECN NO OR DESCRIPTION	REVISED	DATE
A	PDR RELEASE	EVEN	2017.05.18

- SPECIFICATIONS:
1. TO CONFORM TO THE SINGATRON HAZARDOUS SUBSTANCE FREE SPEC.
 2. GREEN PRODUCT IDENTIFICATION LABEL ON PACKAGING: **G.P. PASS**
 3. PACKAGE: SEE "2KJ1538-000112H" PACKAGE.
 4. FOR REFLOW SOLDERING LEAD-FREE PROCESS.
 5. OTHER GENERAL SPEC. TO REFER "2KJ1538-000112H SPEC".

PART NO.
2KJ1538-000112H

SUFFIX: HALOGEN
PACKAGE
1: TRAY
HOUSING COLOR
1: BLACK
CONTACT PLATING
1: TIN

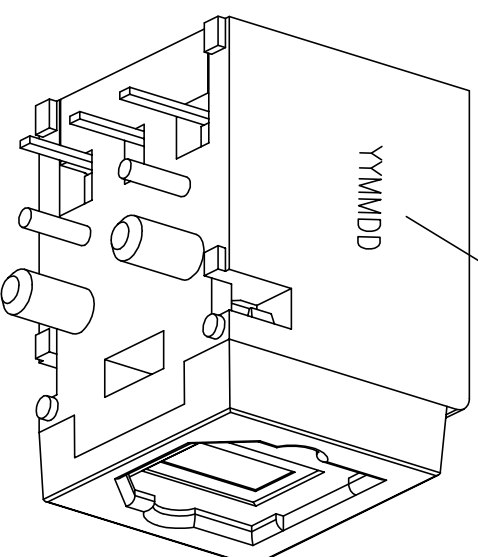
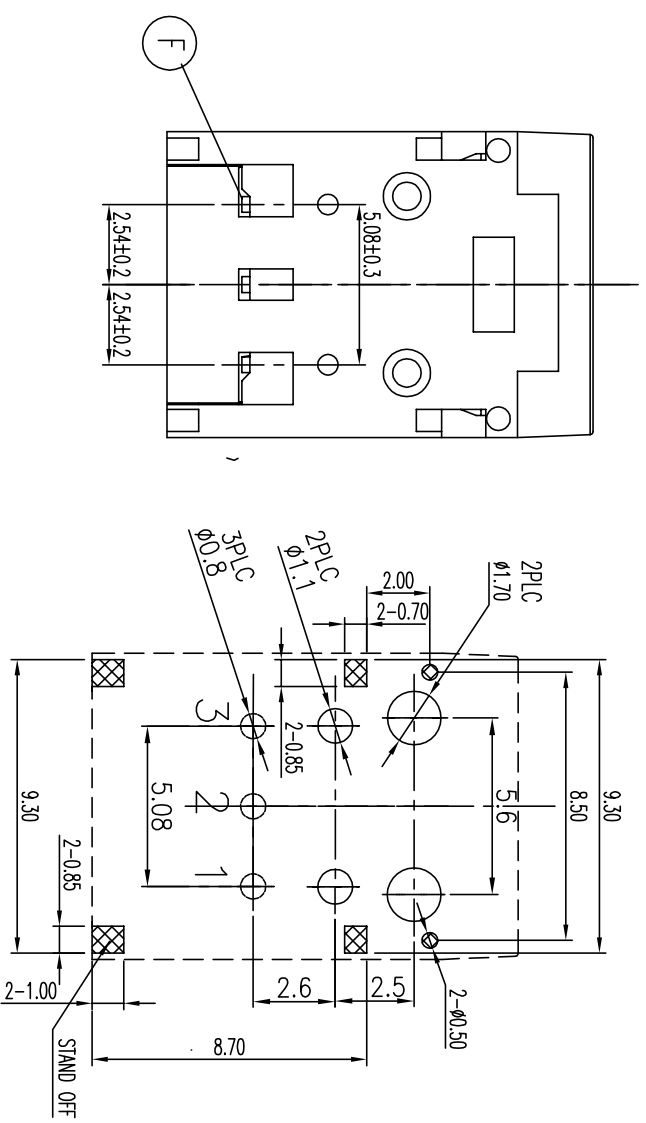
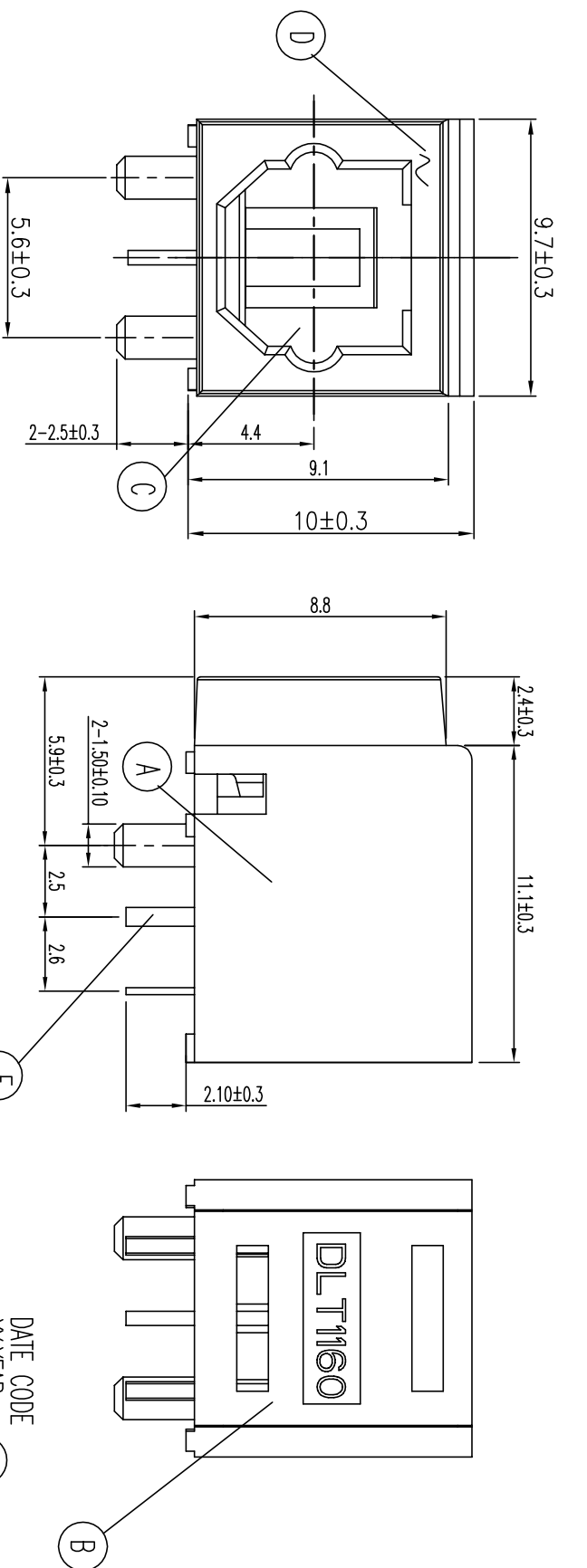

Recommended PCB Layout
Bottom view

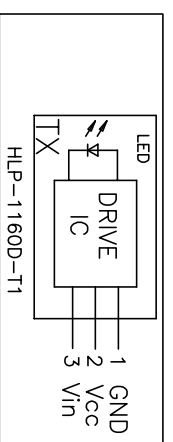

G	INK			BLACK
F	DRIVE IC(TX)	1	25Mbps	
E	PIN	2	SPCC	TIN 60u" Min.
D	SPRING	1	STAINLESS STEEL	
C	GATE	1	PA9T UL94-V0	BLACK
B	FRAME	1	PA9T UL94-V0	BLACK
A	HOUSING	1	PA9T UL94-V0	BLACK
NO	DESCRIPTION	QTY	MATERIAL	PLATING & COLOR

UNLESS OTHERWISE SPECIFIED TOLERANCES

DECIMALS:	ANGLES:
X :±0.5	X :±2°
X.X :±0.3	X.X :±1°
X.XX :±0.2	

TITLE	OPTICAL JACK
DWN	ENEN 2017.05.18
CHKD	ANGEL2017.05.18
APVD	ANGEL2017.05.18

PART NO. **2KJ1538-000112H**

SCALE: 2.2/1 UNIT: mm

SIZE: A3 SHEET: 1 OF 1 REV: A

Singatron Enterprise Co., Ltd.
信亨企業股份有限公司

CUSTOMER COPY

1 2 3 4 5

6

7

8