

REV.	ECN NO OR DESCRIPTION	REVISED	DATE
A	PDR RELEASE	Even	2017.10.20

- SPECIFICATIONS:
- TO CONFORM TO THE SINGATRON HAZARDOUS SUBSTANCE FREE SPEC.
 - GREEN PRODUCT IDENTIFICATION LABEL ON PACKAGING: **G.P. PASS**
 - PACKAGE: SEE "2KJ1543-000111H" PACKAGE.
 - OTHER GENERAL SPEC. TO REFER "2KJ1543-000111H SPEC"
 - FOR WAVE SOLDERING LEAD-FREE PROCESS.

PART NO.
2KJ1543-000111H

SUFFIX: HALOGEN
PACKAGE
1: TRAY
HOUSING COLOR
1: BLACK

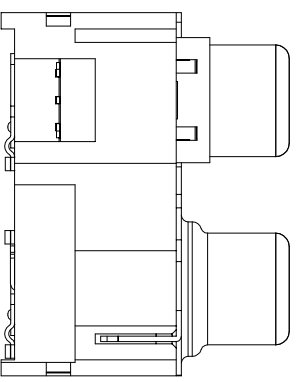
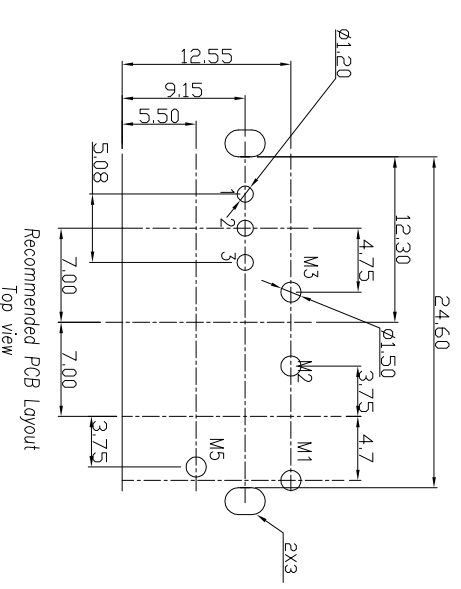
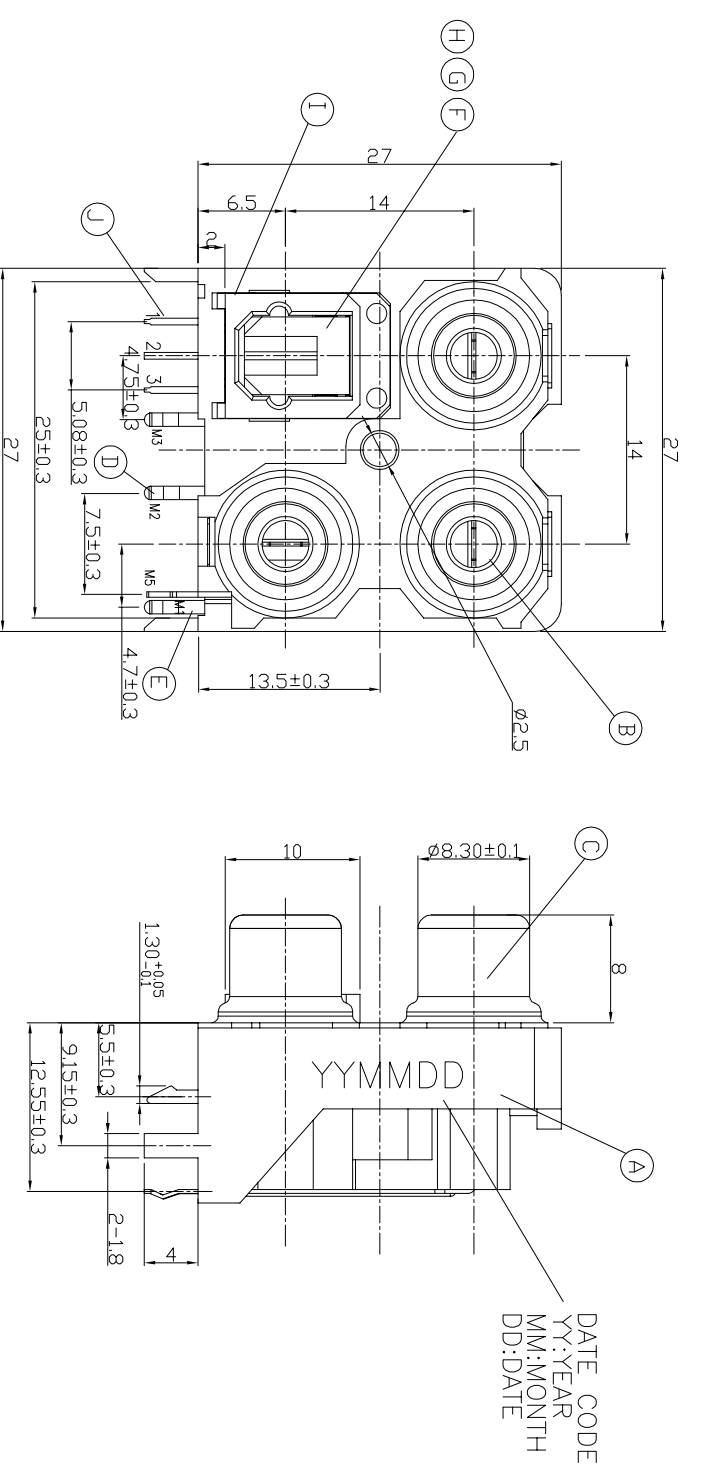
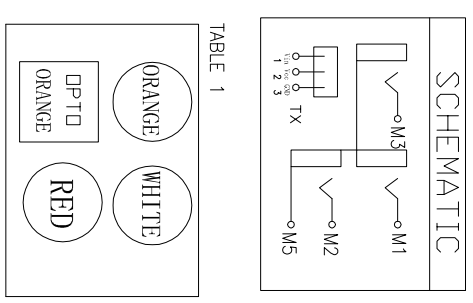

J	TERMINAL-OPTO	1	DRIVE IC	TIN100U"MIN,OVER Ag30U"MIN
I	HOUSING-OPTO	1	PBT UL 94V-0	BLACK
H	SPRING CATCH	1	C2680	
G	SPRING	1	SUS 301	
F	GATE	1	PBT UL 94V-0	ORANGE
E	TERMINAL	2	C2680	TIN80U"MIN,OVER Ni30U"MIN
D	TERMINAL	1	C2680	TIN80U"MIN,OVER Ni30U"MIN
C	SLEEVE	1	C2680	Ni:50U"MIN
B	WASHER	3	PBT UL 94V-0	SEE"TABLE"
A	HOUSING	1	PA9T UL 94V-0	BLACK
NO	DESCRIPTION	QTY	MATERIAL	PLATING & COLOR

UNLESS OTHERWISE SPECIFIED TOLERANCES

Singatron Enterprise Co., Ltd.
信音企業股份有限公司

DECIMALS:	ANGLES:	TITLE	RCA JACK+OPTO
X :±0.5	X :±2°	DWN	ENEN 2017.10.20
X.X :±0.3	X.X :±1'	CHKD	ANGEL2017.10.20
X.XX :±0.2		APVD	ANGEL2017.10.20

PART NO. 2KJ1543-000111H

SCALE:2.2/1 UNIT: mm

SIZE: A3 SHEET:1 OF 1 REV: A

CUSTOMER COPY