

REV.	ECN NO OR DESCRIPTION	REVISED	DATE
A	PRODUCT RELEASE	Victor	2011.02.10
B	ECN NO : T110037	Victor	2011.10.11
C	ECN NO : T120045	Victor	2012.05.10

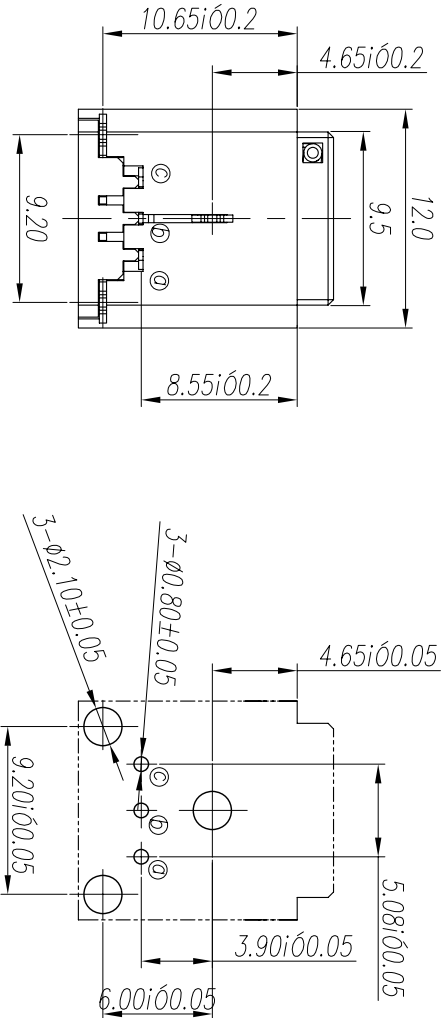
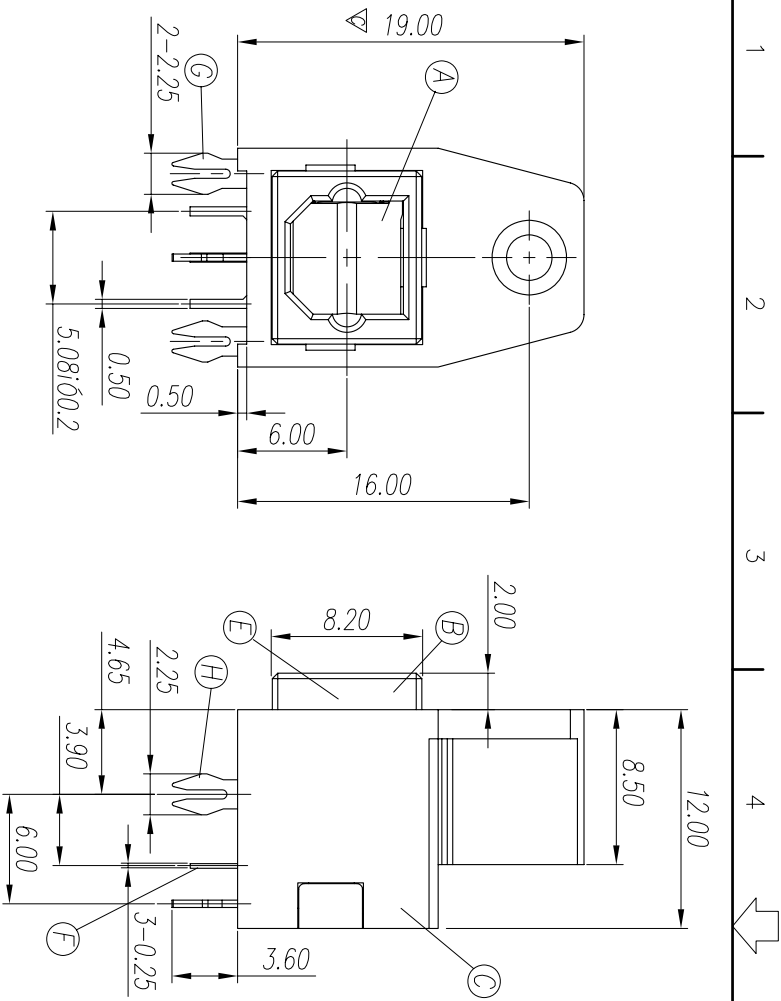
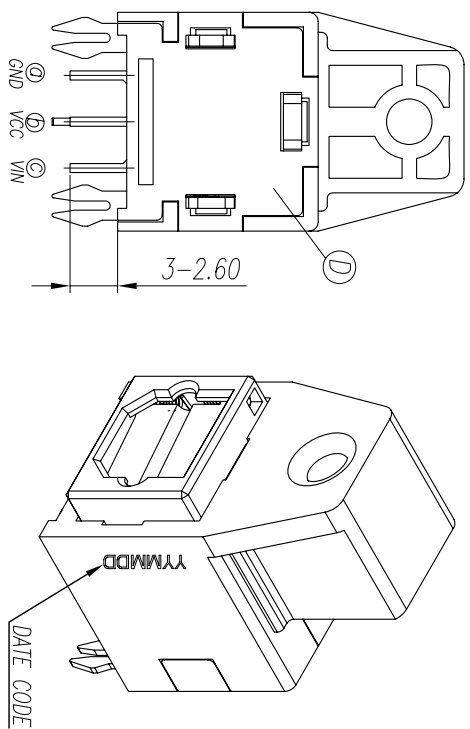

Recommended P.C.B Layout
(BOTTOM VIEW)

- SPECIFICATIONS:
1. GREEN PRODUCT IDENTIFICATION LABEL ON PACKAGING: **G.P. PASS**
 2. FOR WAVE SOLDERING LEAD-FREE PROCESS.
 3. TO CONFORM TO SINGATRON HAZARDOUS SUBSTANCE FACE SPECIFICATION.
 4. PRINTED DATE CODE "YMMDD" ON TOP OF CONNECTOR.
 5. PACKAGING : TUBE.

NO	DESCRIPTION	QTY	MATERIAL	PLATING & COLOR
H	HOOK	1	COPPER ALLOY	NI (60u"Min.) PLATING
G	HOOK	1	COPPER ALLOY	NI (60u"Min.) PLATING
F	IC DRIVE	1	N/A	N/A
E	SPRING	1	STAINLESS STEEL	N/A
D	BASE	1	TERMOPLASTIC UL94V-0	BLACK
C	HOUSING	1	TERMOPLASTIC UL94V-0	BLACK
B	COVER	1	TERMOPLASTIC UL94V-0	BLACK
A	DOOR	1	TERMOPLASTIC UL94V-0	TIME GREEN

UNLESS OTHERWISE SPECIFIED TOLERANCES

Singatron Enterprise Co., Ltd.
 信晉企業股份有限公司

DECIMALS:	ANGLES:
X : ±0.5	X : ±2°
X.X : ±0.3	X.X : ±1'
X.XX : ±0.2	

TITLE	OPTICAL JACK
DWN	WCRP
CHKD	GEAR
APVD	ANGELA 2012.5.11
SCALE:1:1 UNIT: mm	
SIZE: A3 SHEET:1 OF 1	
REV: C	

CUSTOMER COPY