

REV.	ECN NO.	OR DESCRIPTION	REVISED	DATE
B	ECN NO.940223		BERYL	2005.10.5
C	ECN NO.940283		Cornie	2005.11.29
D	ECN NO.L080112		BONNIE	2008.11.05

- SPECIFICATIONS:
1. SEE 20J-0103-301 SPECIFICATIONS.
  2. SOLDER HEAT RESISTANCE: WAVE SOLDERING 260°C 10SECS.
  3. TO CONFORM TO SINGATRON HAZARDOUS SUBSTANCE FREE SPEC.
  4. GREEN PRODUCT IDENTIFICATION LABEL IN PACKING: **G.P. PASS**
  5. FOR LEAD-FREE PRODUCT.

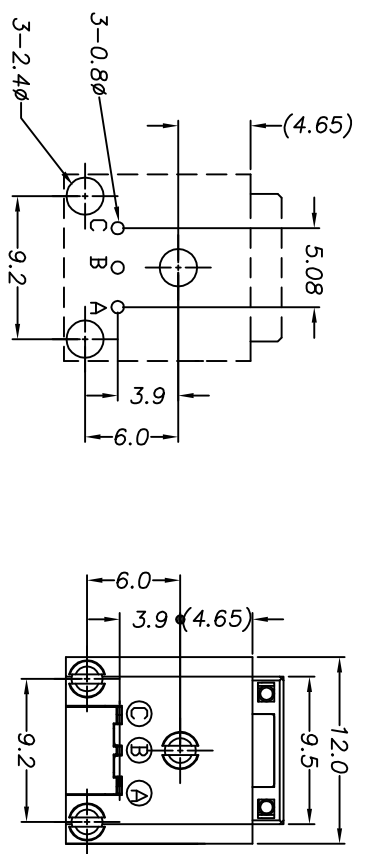

RECOMMENDED PCB LAYOUT  
BOTTOM VIEW (TOLERANCE:±0.05)

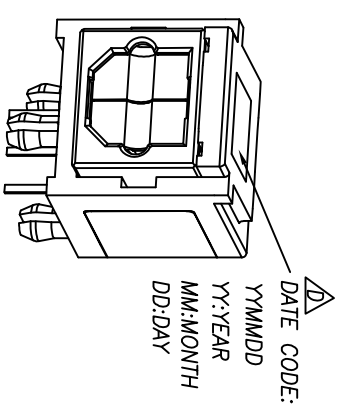
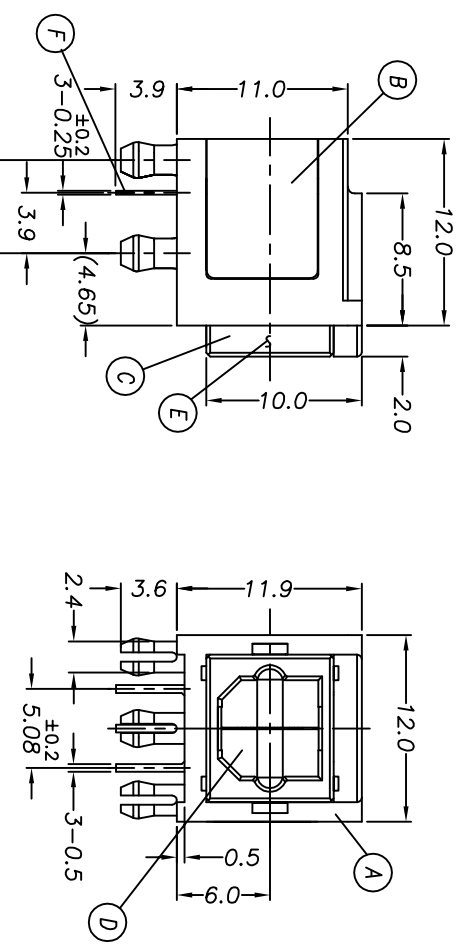
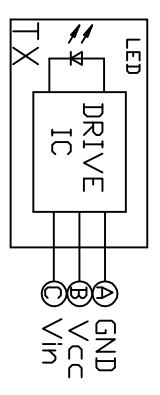

F	TX UNIT	1	COPPER ALLOY 0.25t	TIN PLATING
E	COIL SPRING	2	SUS 301	
D	GATE	2	PA-66 UL94V-0	BLACK COLOR
C	FRAME	1	PA-66 UL94V-0	BLACK COLOR
B	COVER	1	PA-9T UL94V-0	BLACK COLOR
A	BODY	1	PA-9T UL94V-0	BLACK COLOR
NO	DESCRIPTION	QTY	MATERIAL	PLATING & COLOR

UNLESS OTHERWISE SPECIFIED TOLERANCES

Singatron Enterprise Co., Ltd.  
信音企業股份有限公司

DECIMALS:	ANGLES:
X :±0.5	X :±2°
X.X :±0.3	X.X :±1°
X.XX :±0.2	

TITLE	OPTICAL JACK
DWN	DATE: 2005.10.5
CHKD	PART NO. 20J-0103-301
APVD	SCALE: 3/1
	UNIT: mm
	SIZE: A3
	SHEET: 1 OF 1
	REV: D

CUSTOMER COPY