

REV.	ECN NO	OR DESCRIPTION	REVISED	DATE
C	ECN NO.T070160		LULU	2007.09.28

- SPECIFICATIONS:
1. SEE "20J-010X SERIES" SPECIFICATIONS.
 2. SOLDER HEAT RESISTANCE: WAVE SOLDERING 260°C 10 SECS.
 3. TO CONFORM TO THE "SE-01-001" & "ROHS DIRECTIVE"
 4. GREEN PRODUCT IDENTIFICATION LABEL IN PACKING: **G.P. PASS**
 5. FOR WAVE SOLDERING LEAD-FREE PROCESS.
 6. RECOMMEND SCREW TYPE : M3xP1.06 (THE MAX. TORQUE: 5kg-m)

△ DATE CODE:
 YYMMDD
 YY:YEAR(06~)
 MM:MONTH(01~12)
 DD:DAY(01~31)

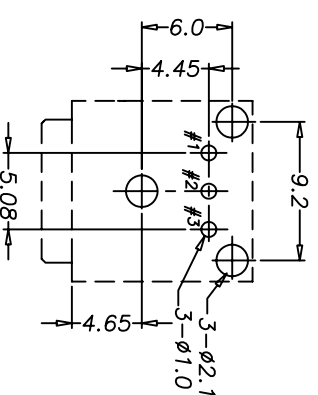
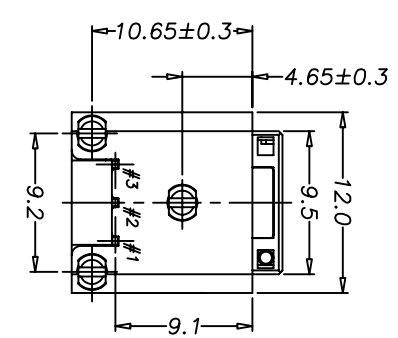
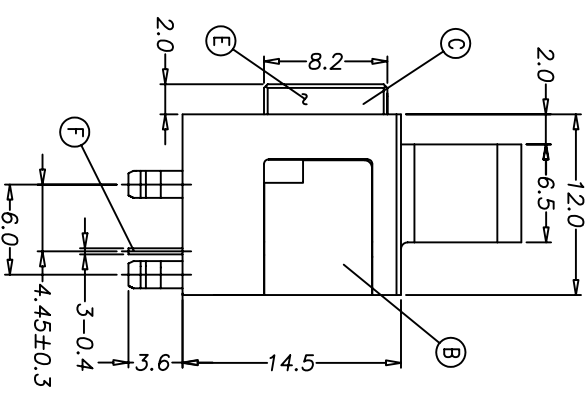
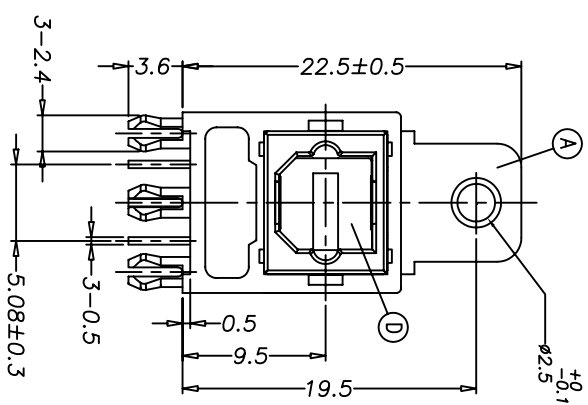
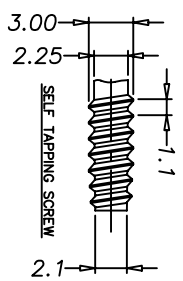
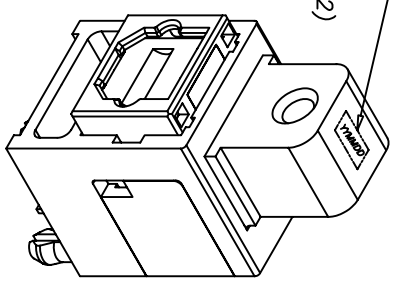

Recommended PCB Layout
 <TOP VIEW> TOLERANCE:±0.05

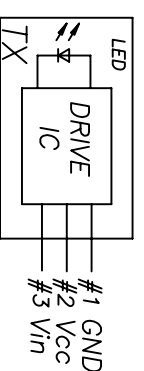

F	DRIVE IC (TX UNIT)	1			
E	COIL SPRING	1	SUS 301		
D	GATE	1	PA-66	GREEN COLOR	
C	FRAME	1	PA-66	BLACK COLOR	
B	COVER	1	PBT UL 94V-0	BLACK COLOR	
A	HOUSING	1	PBT UL 94V-0	BLACK COLOR	
NO	DESCRIPTION	QTY	MATERIAL	PLATING & COLOR	

UNLESS OTHERWISE SPECIFIED TOLERANCES

Singatron Enterprise Co., Ltd.
 信音企業股份有限公司

DECIMALS:	ANGLES:	TITLE	OPTICAL JACK
X : ±0.5	X : ±2°	DWN	LULU 2007.09
X.X : ±0.3	X.X : ±1°	CHKD	AMKX 2007.09
X.XX : ±0.2		APVD	AMKX 2007.09

PART NO. 20J-0104-K01
 SCALE: 3/1 UNIT: mm
 SIZE: A3 SHEET: 1 OF 1 REV: C

CUSTOMER COPY