

REV.	ECN NO.	OR DESCRIPTION	REVISED	DATE
A	PDR	RELEASE	LULU	2008.03.24

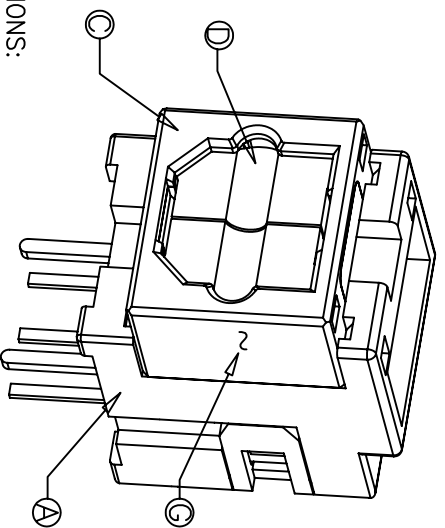

SPECIFICATIONS:

1. SOLDER HEAT RESISTANCE: WAVE SOLDERING 260°C 10 SECS.
2. TO CONFORM TO THE "SINGATRON HSF SPECIFICATION"
3. GREEN PRODUCT IDENTIFICATION LABEL IN PACKING: G.F. PASS
4. SEE "20U1518 SERIES" SPECIFICATION
5. PACKAGE : SEE "20U1518 SERIES" PACKAGE.

PART NO.
20U1518-011111

- PACKAGE 1: TOBE
- HOUSING COLOR 1: BLACK
- CONTACT PLATING 1: TTN PLATING
- GATE COLOR 1: LIME(577C)
- DRIVE IC 1: TX

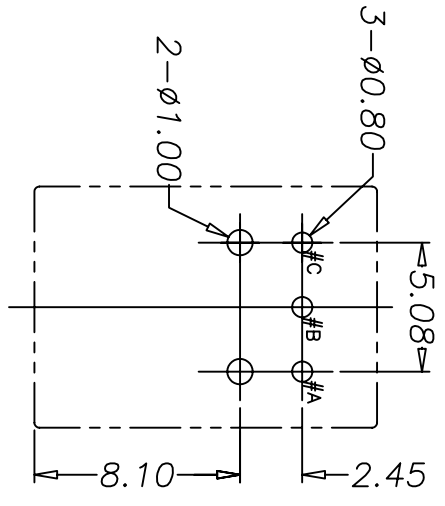
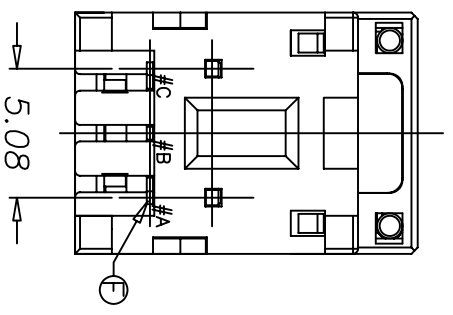
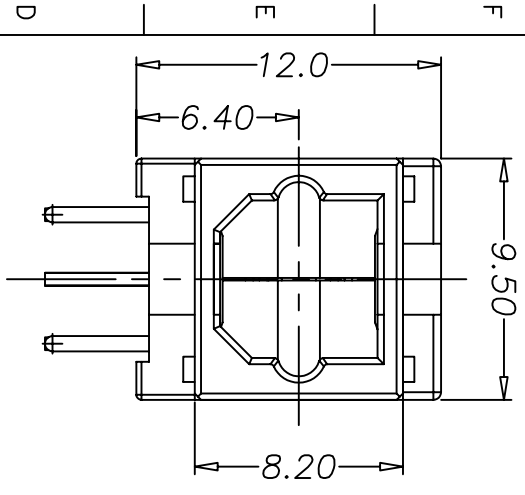
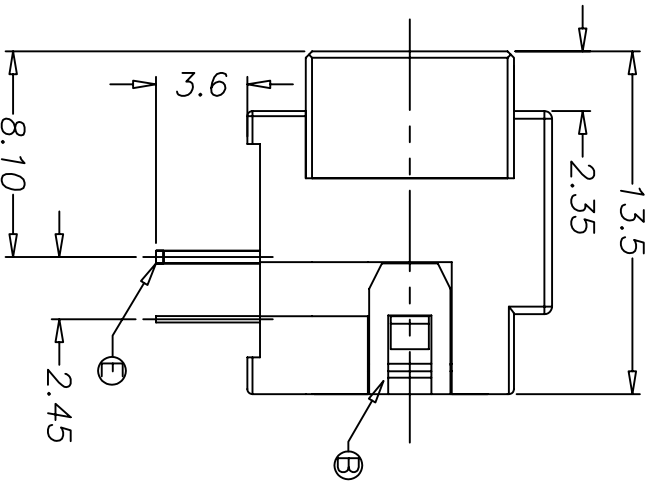

RECOMMENDED PCB LAYOUT
<TOP VIEW>
NOTE : TOLERANCE FOR PCB LAYOUT IS ± 0.05

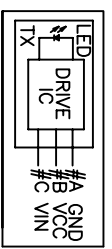

G	COIL SPRING	2	SUS 304	
F	DRIVE IC(TX UNIT)	1		
E	SUPPORT	1	BRASS C2680	TIN PLATING
D	GATE	2	PA66	LIME(577C) COLOR
C	FRAME	1	PA66	BLACK COLOR
B	COVER	1	PBT	BLACK COLOR
A	HOUSING	1	PBT	BLACK COLOR
NO	DESCRIPTION	QTY	MATERIAL	PLATING & COLOR

UNLESS OTHERWISE SPECIFIED TOLERANCES

Singatron Enterprise Co., Ltd.
信音企業股份有限公司

TITLE	OPTO JACK
DWN	LULU 2008.03.23 PART NO.20U1518-011111
CHKD	JMNSM2008.03.23 SCALE:1/1 UNIT: mm
APVD	JMNSM2008.03.23 SIZE: A3 SHEET: 1 OF 1 REV:A

CUSTOMER COPY