

REV.	ECN NO.	OR DESCRIPTION	REVISED	DATE
A	PDR NO.20050922-2		BERYL	2005.10.15

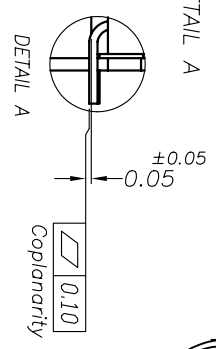

- SPECIFICATIONS:
1. SEE 25J-A001-T01 SPECIFICATIONS.
 2. PACKING: TAPE & REEL.
 3. TO CONFORM TO THE "SE-01-001" & "ROHS DIRECTIVE"
 4. GREEN PRODUCT IDENTIFICATION LABEL IN PACKING: **G.P. PASS**
 5. FOR LEAD-FREE PROCESS.

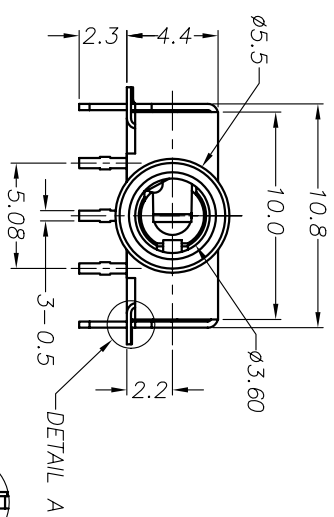
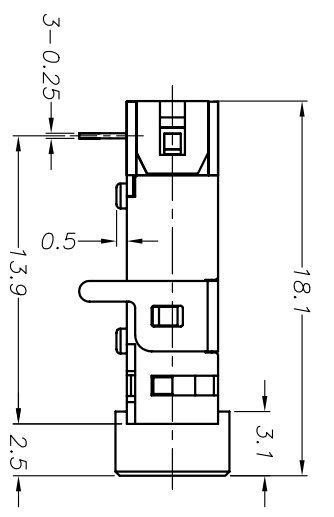
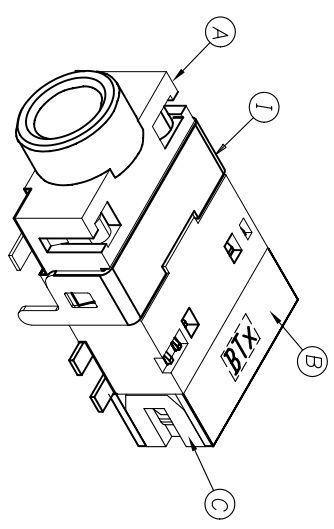
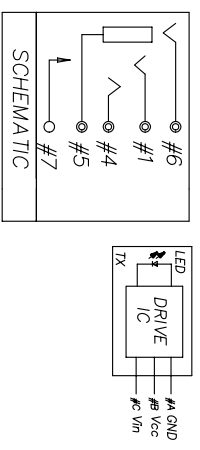
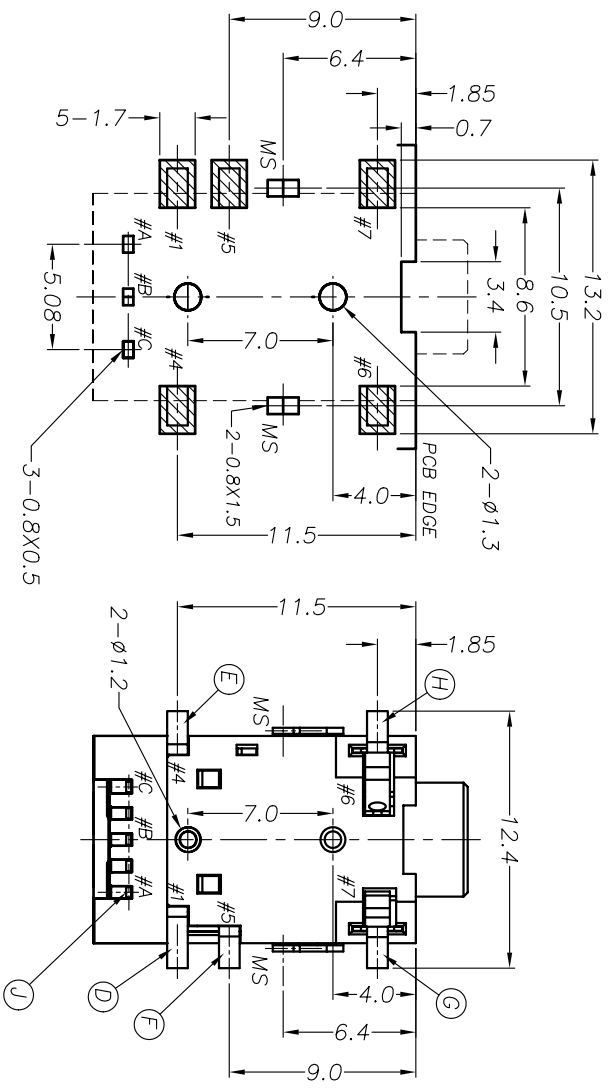

J	DRIVE IC TX	1		
I	SHIELDING	1	BRASS 0.3t	TIN PLATING 100u" ON SOLDER TAIL ALL OVER NICKEL PLATING.
H	EARTH SPRING-B	1	PHOSPHOR BRONZE 0.2t	GOLD FLASH
G	EARTH SPRING-A	1	PHOSPHOR BRONZE 0.2t	GOLD FLASH
F	EARTH TERMINAL	1	COPPER ALLOY 0.2t	GOLD FLASH
E	TIP SPRING	1	COPPER ALLOY 0.3t	GOLD FLASH
D	RING SPRING	1	PHOSPHOR BRONZE 0.25t	GOLD FLASH
C	COVER	1	PA-9T UL 94V-0	BLACK COLOR
B	CASE	1	PA-9T UL 94V-0	BLACK COLOR
A	BODY	1	PA-9T UL 94V-0	BLACK COLOR
NO	DESCRIPTION	QTY	MATERIAL	PLATING & COLOR

UNLESS OTHERWISE SPECIFIED TOLERANCES

DECIMALS: ANGLES:

X :±0.5 X :±2°
X.X :±0.3 X.X :±1°
X.XX :±0.2

TITLE: **Ø3.5 PHONE JACK**

DWN: BERL 2005.10.21 PART NO. **25J-A001-T01**

CHKD: KM 2005.10.21 SCALE: 4/1 UNIT: mm

APVD: AM 2005.10.24 SIZE: A3 SHEET: 1 OF 1 REV: A

CUSTOMER COPY

Singatron Enterprise Co., Ltd.
信亨企業股份有限公司