

- SPECIFICATIONS:
- ELECTRICAL CHARACTERISTICS:
    - RATING: 12V 1A
    - CONTACT RESISTANCE: 30mΩ MAX (INITIAL).
    - DIELECTRIC VOLTAGE WITHSTAND: 500V AC FOR ONE MINUTE
    - INSULATION RESISTANCE: 100MΩ MIN. MEASURED BY 500 VDC
  - MECHANICAL CHARACTERISTICS:
    - INSERTED FORCE : 3.5 KG MAX.
    - WITHDRAWAL FORCE : 0.3~4.0 KG.

- PACKAGING: TAPE & REEL
- TO CONFORM TO SINGATRON HAZARDOUS SUBSTANCE FREE SPEC.
- HALONGEN FREE PRODUCT IDENTIFICATION MARK ON JACK: Ⓞ
- HALONGEN FREE PRODUCT IDENTIFICATION LABEL ON PACKAGING: Ⓞ
- FOR LEAD-FREE PROCESS.

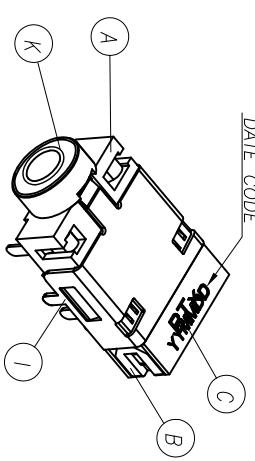

DATE CODE

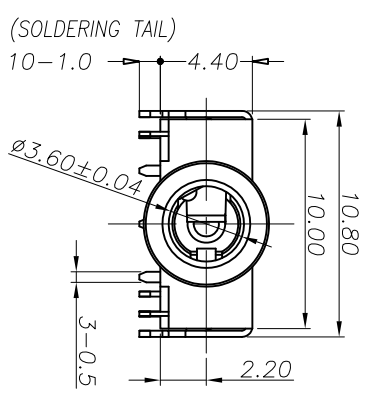
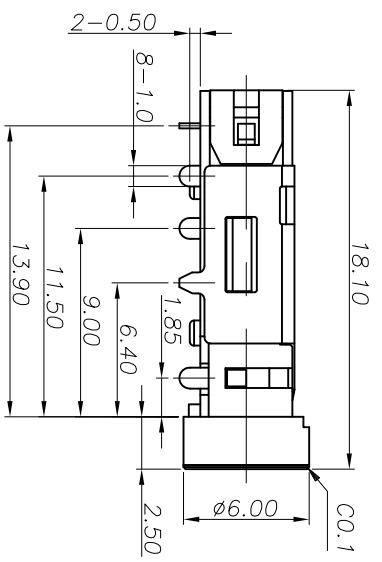

SCHEMATIC

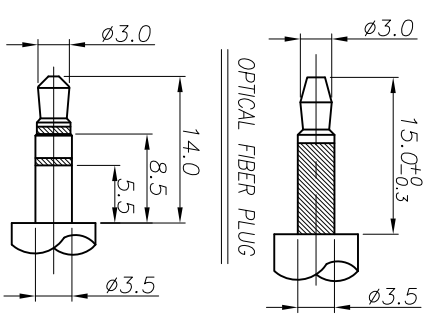
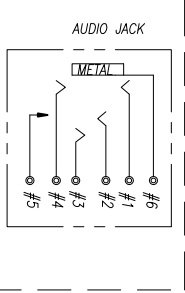

RECOMMEND MATING PLUG

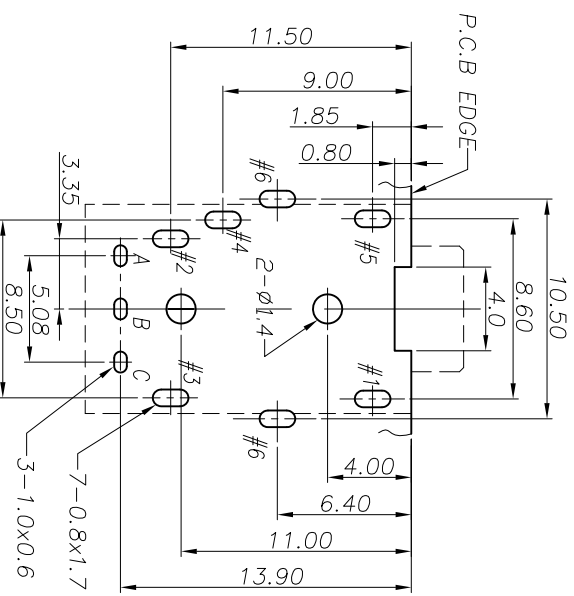

RECOMMEND PCB LAYOUT  
TOP VIEW (TOLERANCE: ±0.05)

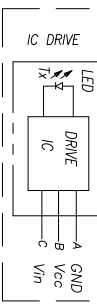
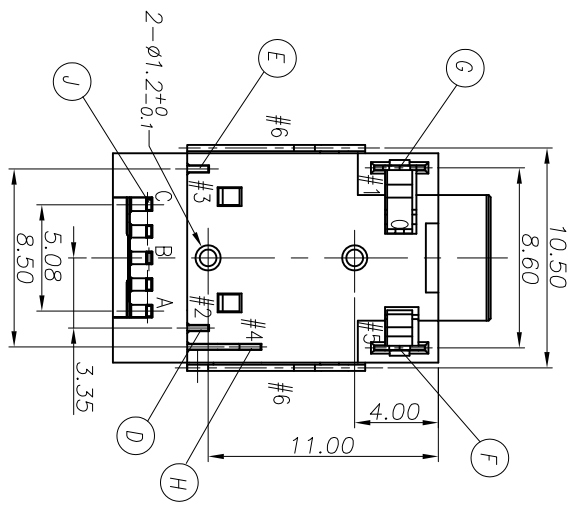

K	METAL	1	BRASS	Ni 80u"
J	IC DRIVE	1	EPOXY	Mathe Sn 120u" OVER Ni 50u"
I	SHIELDING	1	PHOSPHOR BRONZE 0.3T	Ni 60u"
H	EARTH SPRING-A	1	PHOSPHOR BRONZE 0.25T	GOLD FLASH OVER Ni 50u"
G	EARTH SPRING-B	1	PHOSPHOR BRONZE 0.2T	GOLD FLASH OVER Ni 50u"
F	EARTH TERMINAL	1	PHOSPHOR BRONZE 0.2T	GOLD FLASH OVER Ni 50u"
E	TIP SPRING	1	PHOSPHOR BRONZE 0.25T	GOLD FLASH OVER Ni 50u"
D	RING SPRING	1	PHOSPHOR BRONZE 0.25T	GOLD FLASH OVER Ni 50u"
C	CASE	1	HIGH TEMP THERMOPLASTIC UL 94V-0	BLACK
B	COVER	1	HIGH TEMP THERMOPLASTIC UL 94V-0	BLACK
A	BODY	1	HIGH TEMP THERMOPLASTIC UL 94V-0	BLACK
NO	DESCRIPTION	QTY	MATERIAL	PLATING & COLOR

UNLESS OTHERWISE SPECIFIED TOLERANCES

SINGATRON ENTERPRISE CO., LTD.  
信普企業股份有限公司

DECIMALS: ANGLES:

X ±0.5 X ±2°  
X.X ±0.3 X.X ±1'  
X.XX ±0.2

TITLE: 3.5 PHONE JACK (WITH IC)  
PART NO. 2SJ-A373-T13F  
SCALE: 4:1 UNIT: mm  
APVD Max SIZE: A3 SHEET: 1 OF 1 REV: A

CUSTOMER COPY

REV.	ECN NO OR DESCRIPTION	REVISED	DATE
A	PDR NO.:101105-2A	Swing	2011.07.12