

SPECIFICATIONS:

- ELECTRICAL CHARACTERISTICS:
 - RATING: 12V 1A
 - CONTACT RESISTANCE: 30mΩMAX(BEFORE).
 - DIELECTRIC VOLTAGE WITHSTAND: 500V AC FOR ONE MINUTE
 - INSULATION RESISTANCE: 100M MIN. (MEASURED BY 500 VDC)
- MECHANICAL CHARACTERISTICS:
 - INSERTED FORCE : 3.5 KGS MAX.
 - WITHDRAWAL FORCE : 0.3~4.0 KGS
 - LIFE TEST: 5,000 CYCLES MIN.
 - PACKAGING: TAPE & REEL
 - TO CONFORM TO THE SINGATRON HSF SPEC.
 - GREEN PRODUCT IDENTIFICATION MARK ON JACK:
 - GREEN PRODUCT IDENTIFICATION LABEL ON PACKAGING:
 - FOR LEAD-FREE PROCESS.

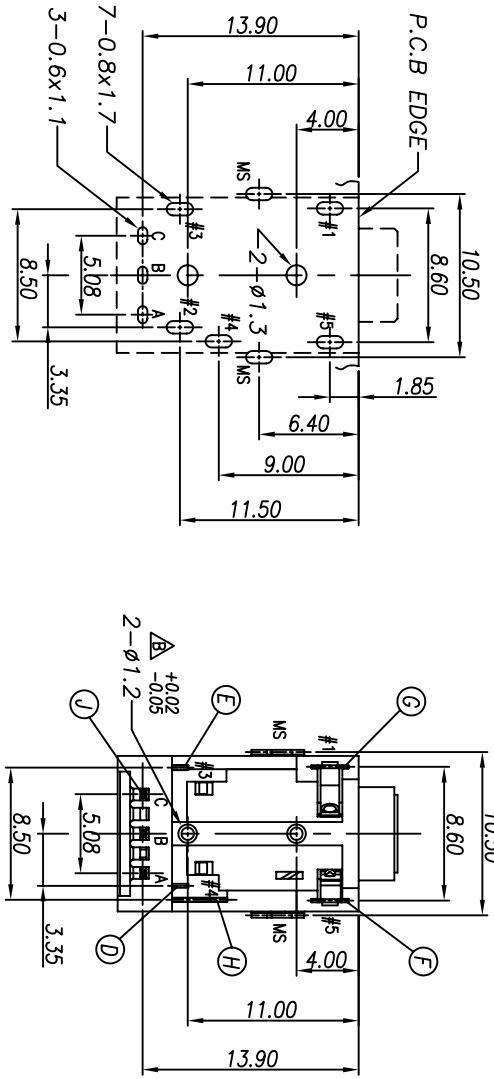

RECOMMENDED PCB LAYOUT
SOLDER SIDE (Tolerance:±0.05)

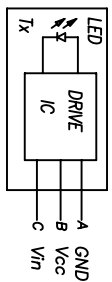
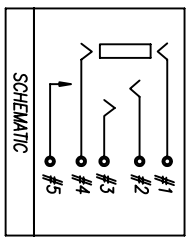
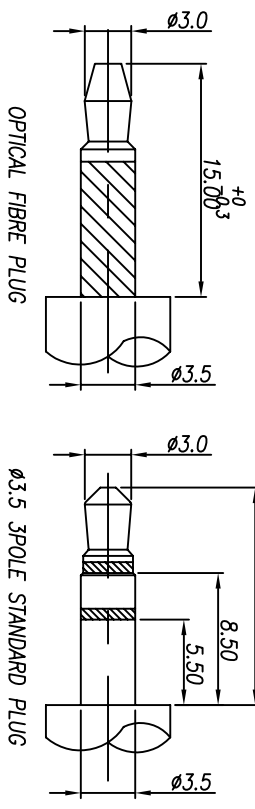

REV.	ECN NO.	OR DESCRIPTION	REVISED	DATE
A		PRODUCT RELEASE	LIAO	2007.03.22
B		ECN NO.1070206	LIAO	2007.07.04
C		ECN NO.1070334	AMY	2007.12.21

L	INSULATION FILM	2	MYLAR	N/A
K	METAL	1	BRASS	NICKEL PLATING
J	IC DRIVE	1	EPOXY	TIN PLATING (Lead-free)
I	SHIELDING	1	BRASS	TIN PLATING 60μm SOLDER TAIL ALL OVER NICKEL PLATING.
H	EARTH SPRING-A	1	PHOSPHOR BRONZE	GOLD FLASH
G	EARTH SPRING-B	1	PHOSPHOR BRONZE	GOLD FLASH
F	EARTH TERMINAL	1	PHOSPHOR BRONZE	GOLD FLASH
E	TIP SPRING	1	PHOSPHOR BRONZE	GOLD FLASH
D	RING SPRING	1	PHOSPHOR BRONZE	GOLD FLASH
C	CASE	1	HIGH TEMP THERMOPLASTIC UL 94V-0	BLACK COLOR
B	COVER	1	HIGH TEMP THERMOPLASTIC UL 94V-0	BLACK COLOR
A	BODY	1	HIGH TEMP THERMOPLASTIC UL 94V-0	BLACK COLOR
NO	DESCRIPTION	QTY	MATERIAL	PLATING & COLOR

UNLESS OTHERWISE SPECIFIED TOLERANCES

DECIMALS: ANGLES:

X :±0.5 X :±2°
 XX :±0.3 XX :±1°
 XXX :±0.2

Singatron Enterprise Co., Ltd.
 信音企業股份有限公司

TITLE: Ø3.5 PHONE JACK (WITH IC)

DWN: MW 2007.12.21 PART NO. 251-E373-TA1
 CHKD: LW 2007.12.21 SCALE: 3/1 UNIT: mm
 APVD: MWBL 2007.12.21 SIZE: A3 SHEET: 1 OF 1 REV: C

CUSTOMER COPY

1 2 3 4 5 6 7 8